



INSTALLATION AND OPERATING INSTRUCTIONS **IL FORNO CLASSICO OVENS**

Series: **FC-516, FC-616 and FC-816**

INTENDED FOR OTHER THAN HOUSEHOLD USE
OVEN MUST BE KEPT CLEAR OF COMBUSTIBLES AT ALL TIMES

RETAIN THIS MANUAL FOR FUTURE REFERENCE

IMPORTANT INSTRUCTIONS

After the gas supply has been connected to your unit, it is extremely important to check piping for possible leaks. To do this, use soap and water solutions, or solutions which are expressly made for this purpose. **DO NOT USE** matches, candles, flames, or other sources of ignitions since these methods are extremely dangerous.

In a prominent location post instructions to be followed in the event you smell gas. Obtain these instructions from your local gas supplier.

FOR YOUR SAFETY

Do not store or use gasoline or other flammable vapors and liquids in the vicinity of this or any other appliance.

WARNING

Improper installation, adjustment, alteration, service or maintenance can cause property damage, injury or death. Read the Installation, Operating and Maintenance Instructions thoroughly before installing or servicing this equipment. Initial heating of oven may generate smoke or fumes and must be done in a well ventilated area. Overexposure to smoke or fumes may cause nausea or dizziness.

NOTE: Only Pizza and Bread Products can have direct contact with Ceramic Decks. All other food products must be placed in pans or containers to avoid direct contact with Ceramic Decks.

This equipment has been engineered to provide you with year round dependable service when used according to the instructions in this manual and standard commercial kitchen practices.

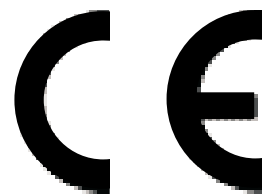

4/03 Form #U4116A

BAKERS PRIDE OVEN CO., INC.

30 Pine Street

New Rochelle, NY 10801

(914) 576-0200 Phone
(914) 576-0605 Fax

(800) 431-2745 US & Canada
www.bakerspride.com WebAddress

INDEX

I. INSTALLATION INSTRUCTIONS

1.	Receiving	3
2.	Clearances	3
3.	Set-up	3
	A. Mounting Legs with Casters	3
4.	Pizza Decks & Optional Ceramic Top	
	A. Three Deck Installation	4
	B. Four Deck Installation	4
	C. Optional Ceramic Top Installation	4
5.	Booster Burner Installation	4
6.	Gas and Electric Connections	4
7.	Main Burner Safety Pilot Operations	5
	A. Pilot Burner Lighting Procedure	5
	B. Pilot Burner Flame Adjustment	5
8.	Burner Operation	5
	A. Main Burner	5
	B. Booster Burner	5
	C. Aeration & By-Pass Flame Adjustment.	5
9.	Thermostat Calibration	6
10.	Flame Diverters	6

II. OPERATING INSTRUCTIONS

1.	Lighting Procedures	6
2.	Breaking-In	6
3.	Baking	
4.	Recommended Operating Procedure	6
5.	Helpful Hints	7

III. CLEANING and MAINTENANCE

1.	Stainless Steel Surfaces	7
2.	Painted Surfaces	7
3.	Door Mechanism	7
4.	Flue Vent	7
5.	Oven Interior	7
	A. Baking Chamber	7
	B. Bake Decks	7
	C. Burner Compartment	8
6.	Parts Breakdown	8
7.	Sales & Service Centers	9
	Installation Figures/Illustrations	10 & 11
	Wiring Diagrams	12

IV. MODELS COVERED

FC-516 Pizza Oven	140,000 BTU/Hr (41 kw)
FC-616 Pizza Oven	140,000 BTU/Hr (41 kw)
FC-816 Pizza Oven	140,000 BTU/Hr (41 kw)

For European Community countries: 230 Volts, 1 Phase, 50 Hz.

EN 437 Gas Cat.	Gases and Supply Pressures	Designated European Market =														
		A T	B E	D K	F I	F R	G R	D E	I E	I T	L U	N L	P T	E S	S E	G B
I2H	G20 @ 20mbar															
I2L	G25 @ 25mbar															
I2E	G20 @ 20mbar															
I2E+	G20/25 @ 20/25mbar															

For North America: 120 or 208/240 Volts, 1 Phase, 60 Hz.

Type of Gas

Natural
LP

Manifold Pressure

3.5" Water Column
10" Water Column

I. INSTALLATION INSTRUCTIONS

1. RECEIVING:

Read the notice on the outside carton regarding damage in transit. Damage discovered after opening the crate(s) / carton(s) is "CONCEALED DAMAGE" and the carrier must be notified immediately to send an inspector and also furnish the forms for the consignee's claim against the carrier.

When oven arrives, it should consist of : A crate, or carton, containing your new oven, a carton, containing 4 legs with mounting hardware, and a strapped skid, containing baking decks.

Installation must conform with local codes and/or with the latest edition of the ANS Z-233.1 National Fuel Gas Code in USA / CAN/CGA-B 149.1 or 2 Installation Code in Canada.

This appliance must be installed by a competent person. In the U.K., Corgi registered Installers (including the regions of British Gas) undertake to work to safe and satisfactory standards. This appliance must be installed in accordance with the current Gas Safety (Installation and Use) Regulations and the relevant Building Regulations / IEE Regulations. Detailed recommendations are contained in the British Standard Codes Of Practice BS 6172, BS 5440:Part 2 and BS 6891.

Place the oven and parts as close as possible to the area of final installation before un-crating.

2. CLEARANCES:

Minimum Clearance From	Combustible Construction	Non-Combustible Construction
Left Side	3" (76 mm)	0
Right Side	1" (25 mm)	0
Rear	3" (76 mm)	2" (51 mm)

Front and Flue Area - Enclose only with non-combustible materials.

- A. Provisions must be made for easy access to the louvered service panel on the left side of the unit. A removable panel at least 16" x 31" (406 x 787 mm) in line with the service panel to facilitate a service man to work will be satisfactory. See installation sketch "A".
- B. Reference to back panels deleted. No longer necessary.
- C. Easy accessibility through the front of the oven to the main burner, oven controls and flue slide push / pull knobs must be provided. See installation sketch "B".

Sketch "A"

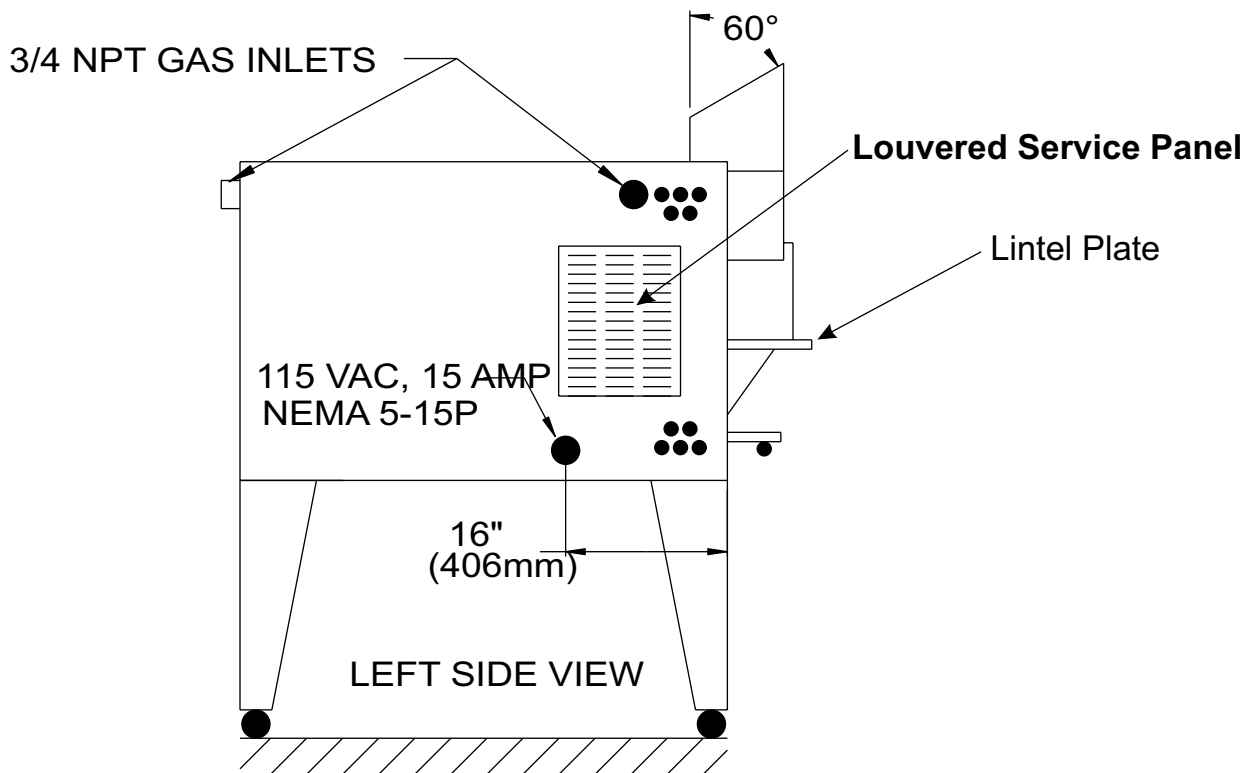

Sketch "B"

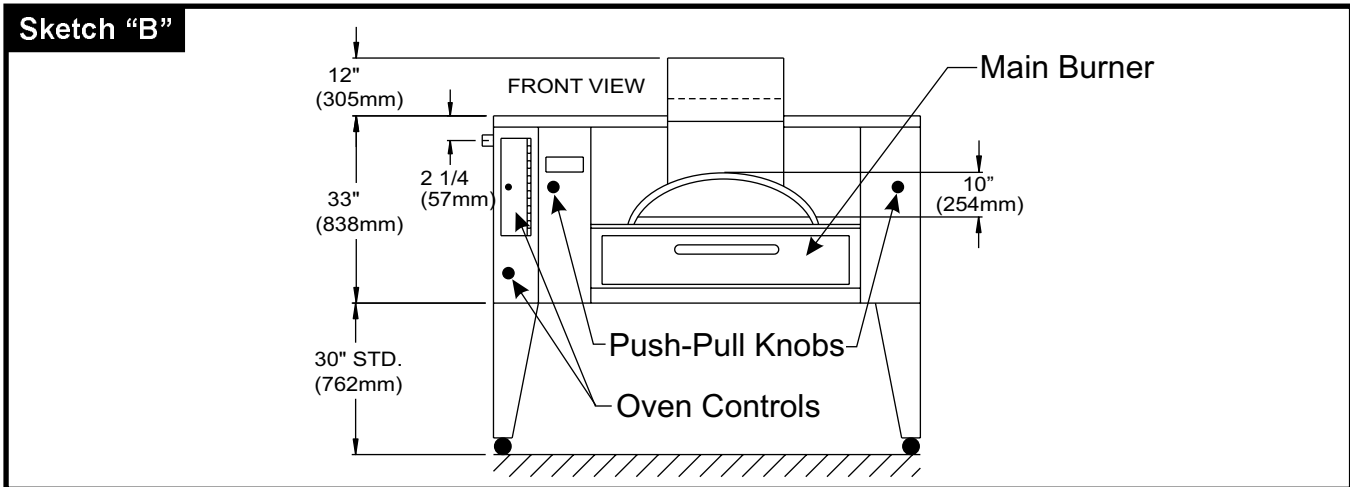

3. SET-UP: The oven must be installed in a well-ventilated area. Your oven is packed standing on its back. Leave in on it's back while unpacking. The skid may be left under the oven for convenience in further handling. Unpack carefully to avoid damage to the oven. If concealed damage is found, follow the instructions detailed in Section 1. Keep the area around the oven free and clear of combustible materials. Do not store any materials on top of or under any oven. Provisions for adequate air supply to your oven for ventilation and proper gas combustion is essential. As a minimum, observe the clearances detailed in Section 2. Provide adequate ventilation and make up air in accordance with local codes.

The oven must be installed under a ventilation hood. Fit the flue diverter (see Sketch "C") into the hole in the top front of the oven and secure with the screws supplied. Local inspectors and ventilation specialists should be consulted to make sure that the installation of the hood conforms to the local codes and requirements (see Sketch "D").

In the U.K., ventilation requirements detailed in BS 5440 should be followed. Access to the bottom front door and left side control panel is required for day to day operation of the oven and for servicing. Make sure that these areas are kept unobstructed for easy access.

Sketch "C"

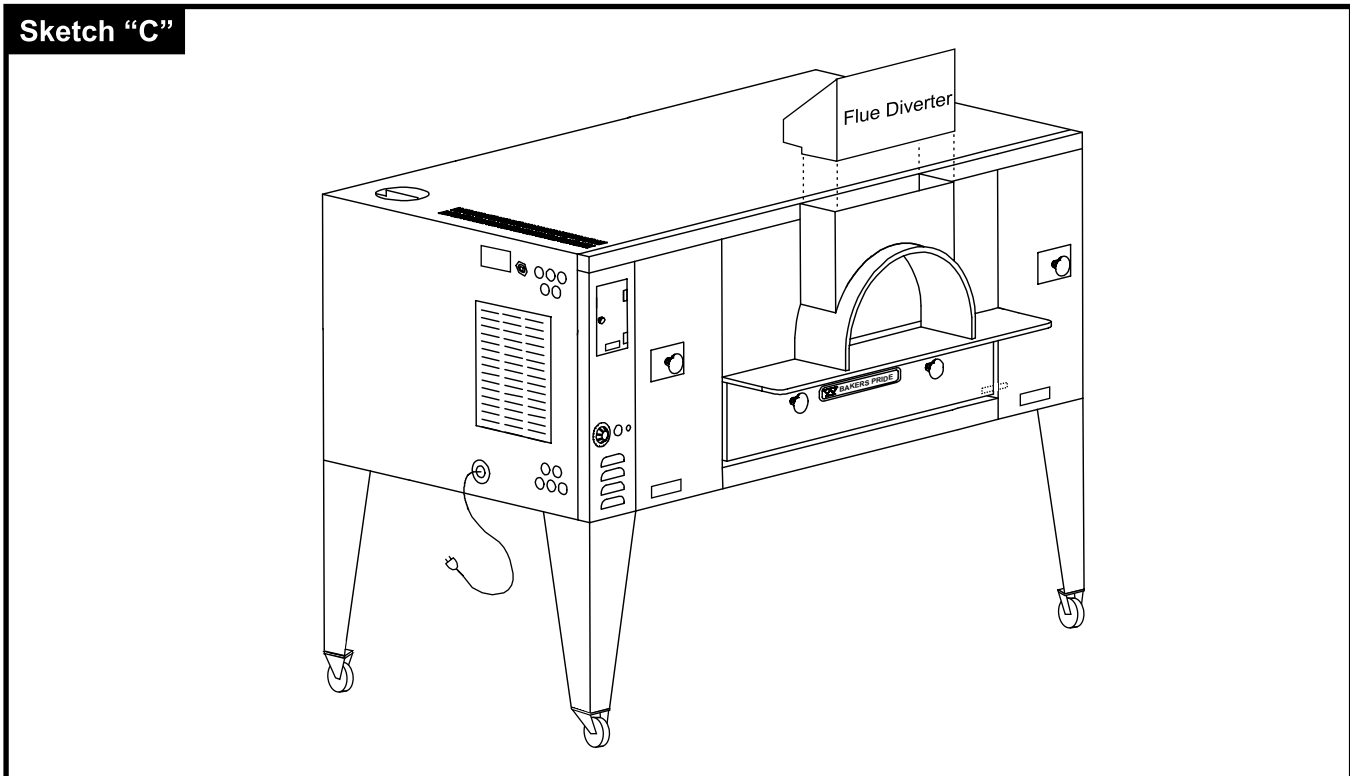

Sketch "D"

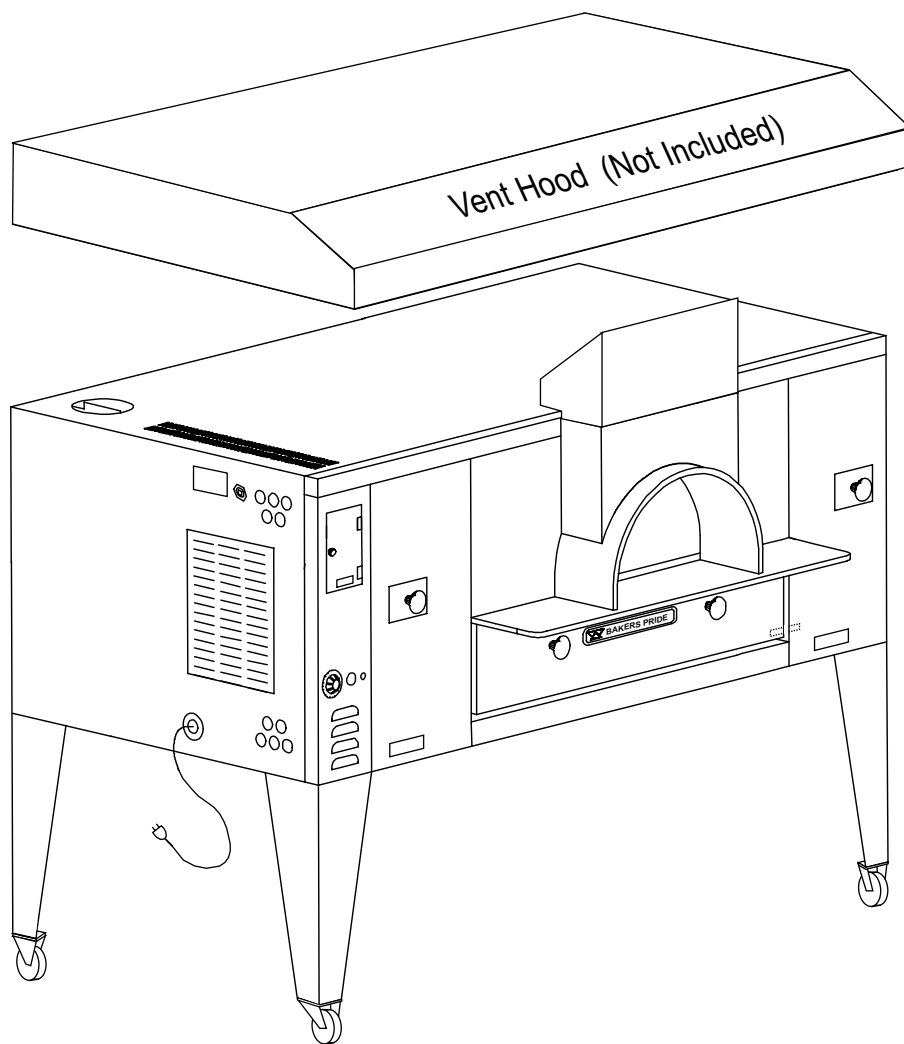

A. MOUNTING LEGSWITH CASTERS:

Legs are shipped in a separate carton complete with mounting hardware and casters, (two of them with wheel brakes).

NOTE : Installation should be made with a connector that complies with the latest edition of the Standard for Connectors for Movable Gas Appliances ANSI Z21.69 in the USA (CAN CGA6.16 in Canada) and a quick disconnect device that complies with the latest edition of the Standard for Quick Disconnect Devices for use with gas fuel ANSI Z21.41 in the USA (CAN CGA 1-6.9 in Canada) and adequate means must be provided to limit the movement of the appliance without depending on the connector and any quick disconnect device or its associated piping. The restraint should be attached to the rear legs of the oven on which casters are mounted. If disconnection of the restraint is necessary to move the oven for servicing needs, the restraint should be reconnected after the appliance has been returned to its originally installed position.

- Bolt two (2) legs with casters and wheel brakes firmly to the two (2) upper (front) corners of the oven as it stands on the skid (see Sketch "E").
- Using proper lifting equipment, lower the oven down so that the two bolted legs rest on the floor (see Sketch "F").
- Using proper lifting equipment, raise the back side of the oven to a height slightly higher than the height of the legs, remove the skid and place a sturdy support under the back side (see Sketch "G"). Mount remaining two (2) legs and tighten bolts. Lift the oven and remove the supports.
- Move the oven to its final location, keeping the minimum clearances from the back of the oven to the wall. This clearance is necessary for safe operation and to provide proper air flow to the burner chamber.

Sketch "E"

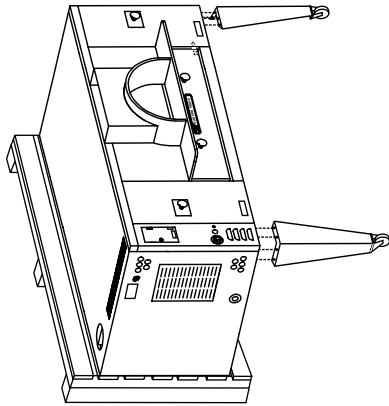

Sketch "F"

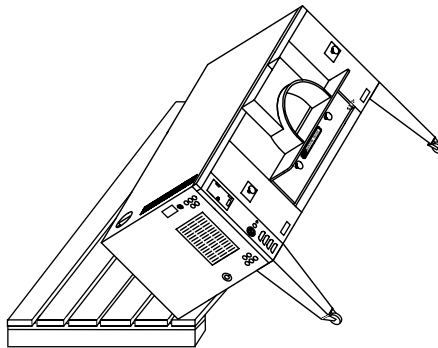

Sketch "G"

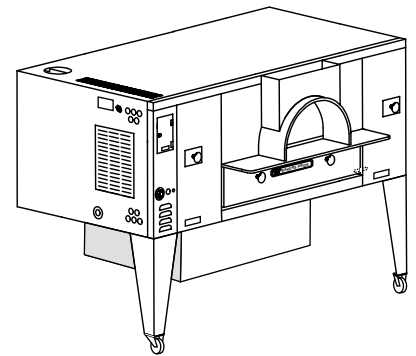

4. PIZZA DECKS AND OPTIONAL CERAMIC TOP:

A) Remove all packaging material, samples, shims, etc., from the bake chamber, leaving the two metal hearth liner sheets in place on the bake chamber floor. Make sure that the two metal hearth liner sheets cover the entire bottom of the chamber.

b) Three (model FC-616) and four (models FC-516 and FC-816) slabs of the Pizza Deck are provided with the oven. This material is heavy and fragile and should be handled carefully.

NOTE 1: When sliding in the slabs, be very careful not to hit the booster burner components at the rear of the bake chamber.

NOTE 2: If the side wedge is pushed in too tightly, the heat control slides, operated by the black knobs located on the front of the oven, will not slide freely.

A. Three Deck Installation: (Model FC-616)

- a) Slide one slab into the bake chamber and push it as far as possible to one side.
- b) Slide the second slab into the bake chamber on the side opposite to the first slab.
- c) Slide the third slab into the center section.
- d) Use metal shims as needed to level the slabs.
- e) Use two wedges in the back and another on one side of the decks. The three slabs should be tight against each other with no gap in between them (See Sketch "H").

Sketch "H"

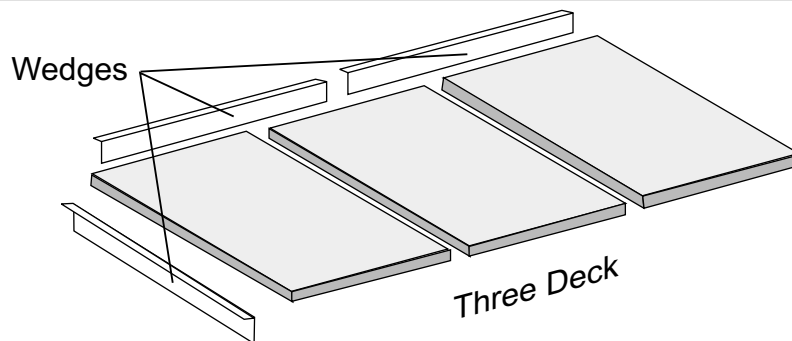

B. Four Deck Installation: (Models FC-516 and FC-816)

- a) Slide one slab into the bake chamber and push it as far as possible to one side towards the rear.
- b) Slide the second slab into the bake chamber and push it next to the first slab in the rear.
- c) Slide the third and fourth slabs in front of the slabs already in place.
- d) Use metal shims as needed to level the slabs.
- e) Use one (FC-516) or two (FC-816) wedges in the back and another on one side of the decks. The four slabs should be tight against each other with no gap in between them (See Sketch "I").

Sketch "I"

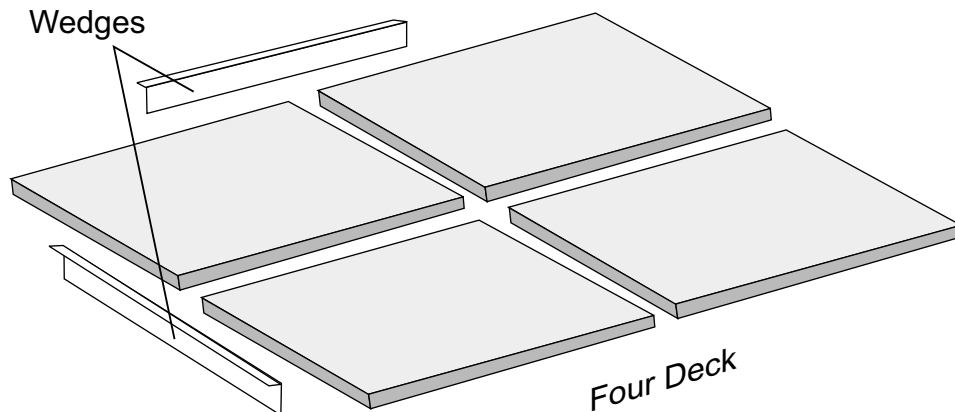

C. Optional Ceramic Top Installation:

If the oven was ordered with the ceramic top option, the two top supports are already installed. Simply slide in the ceramic tops as per instructions below. If this option is an add-on, you must follow the instructions provided with the Ceramic Top Installation kit.

- Through the arched front opening, insert one of the center slabs (20 13/16 x 20 13/16 for FC616 and FC816)(17 1/2 x 17 3/4 (left to right) for the FC516) into the bake chamber, raise one side until the other side comes to rest onto the center support, then lower the first side to lock it in between the two center supports. Push it to the rear as far as possible to make room for the second center slab.
- Install the second center slab (20 13/16 x 20 13/16 for FC816)(14 3/16 x 20 13/16 (left to right) for FC616)(17 1/2 x 17 3/4 (left to right) for FC516) into the bake chamber and push it tightly against the first slab.
- Install the side slabs (20 13/16 x 20 13/16 for FC816)(17 1/2 x 17 3/4 (left to right) for FC616)(17 1/2 x 13 3/4 (left to right) for FC516) in a similar fashion, raising the slab in the center until the lower side edge rests on the side support, then lowering the upper edge onto the center support. First the ones in the rear, then the ones in the front, pushing them tightly against the first slabs.

5. BOOSTER BURNER INSTALLATION:

NOTE: The Booster Burner and the Booster Burner Guard are shipped inside the burner compartment and have to be installed before the booster burner can be used for the first time.

- Once the Pizza Deck Slabs are installed as per instructions above, place the booster burner and guard inside the bake chamber, as far back as possible, then follow with your upper torso and do the following:
- Center the guard in front of the booster burner brackets, flange down, wings back, then push it all the way back and under the booster burner brackets.
- Reach over the guard, slip the throat of the booster burner over the gas nozzle, then lower it and insert the two burner ends into the locating slots of the booster burner brackets and push them all the way down.

6. GAS AND ELECTRIC CONNECTIONS:

NOTE: Propane Gas Units are not available in the European Community.

- Normal factory connections are made for 120 Volts AC, 60 Hz operation in USA and Canada. For use in Europe, the connections are made for 230 Volts AC, 50 Hz operation.
- The appliance, when installed, must be electrically grounded in accordance with local codes and/or the latest edition of the National Electric Code ANSI/NFPA 70 in USA (Canadian Electric Code CSA C22.2 in Canada).
- In Europe, the appliance must be connected by an earthing cable to all other units in the complete installation and thence to an independent earth connection in compliance with EN 60335-1 and/or local codes.

d) The hot surface ignition system, all related switches, indicator light and fuse, are all connected through the 6 ft (1830 mm) power supply cord. The power supply cord must be plugged into a properly grounded three-prong receptacle.

Do not cut or remove the ground prong from the plug.

e) A wiring diagram may be found behind the service panel on the left side of the unit and also in this manual.

f) The ovens should not be installed on the same line with space heaters, boilers or other gas equipment with high intermittent demand.

g) Use a pipe joint compound that is resistant to the action of liquefied petroleum gases when making gas connections.

h) For Propane gas, use a least ½" pipe or tubing with a 5/8" inside diameter. For Natural gas, use ¾" pipe.

i) The appliance must be isolated from the gas supply piping system by closing its manual shut-off valve during any pressure testing of the gas supply piping system at test pressures equal to or less than ½" psig (3.45 kpa).

j) The appliance and its shut-off valve must be disconnected from the gas supply piping system during any pressure testing of that system at test pressures in excess of ½" psig (3.45 kpa).

k) The gas pressure regulators are part of the combination valves and are adjusted to yield a pressure of 3.5" water column (9 mbar) for Natural Gas. If the oven has been ordered for use on Propane Gas, the pressure regulators in the combination valves are preset at the factor to yield a pressure of 10" water column (25 mbar).

l) A separate shut-off valve for each oven must be provided. It should be as close as possible to the place where the gas line enters the oven. It must be located where it is easily and quickly accessible.

m) When stacking with another type of oven, two (2) shut-off valves, one for each of the two ovens, must be provided.

After the gas supply has been connected, it is extremely important to check all the piping for leaks. Use a soap and water solution or a product made expressly for this purpose. Do not use matches, candles or a flame etc. to check leaks since these methods are extremely dangerous.

7. SAFETY PILOT OPERATION:

The purpose of the safety pilot system is to lock the gas supply to the burner at the combination valve, if for any reason the pilot burner is not lit. The pilot should be re-lighted by following the steps given below. However, in normal service, the pilot flame stays lit indefinitely, day and night, including weekends. This prolongs the life of the safety valve.

The safety pilot valve is in effect a two-stage control. After initial lighting, the pilot burner stays on without the gas cock dial being held pressed in. After 1-2 minutes, the valve opens fully to let the gas flow past the safety pilot valve and into the burner system.

A. PILOT BURNER LIGHTING PROCEDURE:

A) Partially depress and turn the gas cock dial to the "OFF" position.

b) Wait for five minutes to allow gas, which may have accumulated in the burner compartment, to escape.

c) Turn gas cock dial to "PILOT" position.

d) Depress gas cock dial.

e) **For Main Burner:** With a match or igniter light pilot burner. Hold gas cock dial in pressed position for about 1/2" minute and then release it. The Pilot Burner flame should now remain lit. If Pilot Burner fails to ignite or does not remain lit, repeat steps (a) thru e).

f) **For Booster Burner:** Flip toggle switch to the "ON" (I) position. The amber indicator lamp will light up and the igniter will be energized and start to glow. Hold gas cock dial in pressed position for about 2-3 minutes and then release it. The Pilot Burner flame should now remain lit. If Pilot Burner fails to ignite or does not remain lit, repeat steps (a) thru (d) and (f).

Note: The built-in igniter is for convenience of lighting only and not necessary for the booster burner operation. In case of power failure, or if the igniter will not light the pilot flame, the pilot flame can also be lit with a long hand-held igniter or with a long, lit taper.

B. PILOT BURNER FLAME ADJUSTMENT:

It is important to have the correct Pilot Burner Flame size as shown in (Sketch "J"). If necessary, adjust the Pilot Burner Flame by turning the Pilot Adjustment Screw (see Sketch "K") clockwise to reduce or counter-clockwise to increase.

Sketch "J"

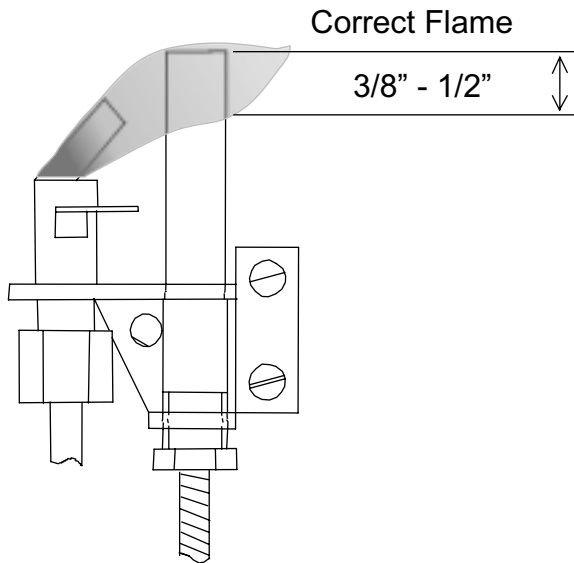

Sketch "K"

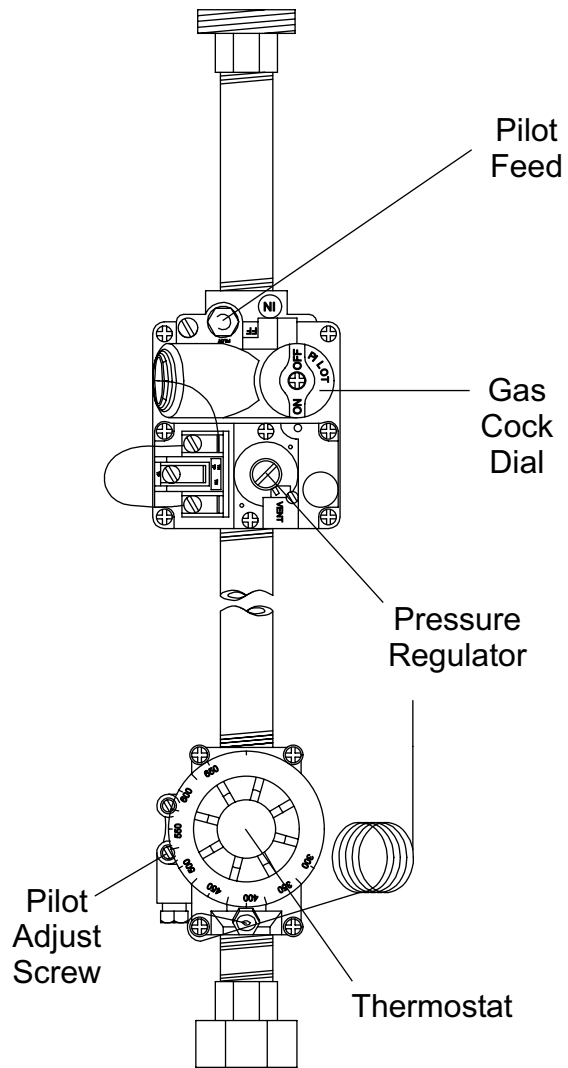

8. BURNER OPERATION:

A. MAIN BURNER:

After the pilot burner is ignited, when heat is desired, turn gas cock dial to the "ON" position and set the thermostat dial to the desired temperature. The oven burner flame should always have a blue appearance. That indicates a good mixture of gas and air. When using LP gas, the flame will have a blue-yellow appearance.

B. BOOSTER BURNER:

Do not turn on the booster burner until the oven is well pre-heated and the pre-set temperature has been reached. The oven has to be hot in order to draw fresh air in to the booster burner.

After the pilot burner is ignited, when the booster burner flame is desired, turn gas cock dial to the "ON" position. The booster burner is set to have a yellow flickering flame, but should not soot.

Should the Burners fail to light, check to see if there is a problem with the gas supply. If there are other appliances on the same line, shut them off temporarily and see if the burners come back on, or they fluctuate as other gas appliances are turned on and off. That would indicate an overload of the gas supply lines or a faulty gas pressure regulator. Contact an authorized Service Agency or your local Gas Supply Company.

C. AERATION and BY-PASS FLAME ADJUSTMENT:

Flame and air mixer adjustments for the Main Burner and the Booster Burner, and the By-Pass Flame adjustment for the Main Burner are all done at the factory. These adjustments are sealed before the oven leaves the factory. Contact an authorized Service Agency if you need help.

9. THERMOSTAT CALIBRATION:

No attempt should be made to calibrate the thermostat because it is accurately calibrated and sealed by the manufacturer. Contact an authorized Service Agency if you need help.

10. FLAME DIVERTERS:

Flame diverters distribute the heat evenly below the baking deck. They must be in good condition and properly placed above the burners in the burner chamber in order to be effective. Damaged or improperly installed flame diverters adversely affect the oven performance. Make sure that the "V-shaped" diverters are pushed all the way to the back of the oven as far as they will go. Check them periodically and replace them as necessary.

II. OPERATING INSTRUCTIONS

If gas odor is detected at any time, immediately shut off the gas supply valve to the oven. Do not permit any open flames in the area of the oven. **Immediately contact an authorized Service Agency or your local Gas Supply Company.**

Initial heating of the oven must be done in a well-ventilated area as it may generate smoke or fumes. Over-exposure to smoke or fumes may cause nausea or dizziness.

1. LIGHTING PROCEDURE:

- a) Light the Main Burner following the instructions in Section 7A of the Installation Instructions.
- b) Keep the Push/Pull Slides fully open.

2. BREAKING IN:

A break-in period, after installing a new oven, is important to allow the deck and the insulation to dry out. Baking in the oven before a break-in period will result in poor performance. For breaking in:

- a) Allow the oven to warm to 300°F (150°C) for 5 hours or at least until all the smoke and fumes have disappeared. The smoke and fumes are from the moisture in the deck and insulation and a light coat of oil on all of the sheet metal.
- b) Set the thermostat at least 50°F (30°C) lower than your baking temperature.
- c) Pre-heat the oven for 1 to 1 ½ hours before use.
- d) After this pre-heating, raise the temperature to your baking temperature.
- e) Light the Booster Burner following the instructions in Section 7B of the Installation Instructions.
- f) Experiment baking until you get the feel of the oven and the speed of the bake.

3. BAKING:

Pizza can be baked on the deck, on a screen or in a pan. When you determine the combination of method, ingredients and temperature that gives the right bake for your crust, sauce and cheese combination and your customer's taste, mark it down and keep it. Consistency is the key to repeat business.

Deck baking refers to placing the pizza directly on the deck to bake. Generally, it is a thin product that requires a high baking temperature of at least 550°F (290°C).

Screen baking refers to placing the pizza on a screen to bake. The screen keeps the pizza off the deck. The screen may be removed near the end of the bake time to give the bottom of the pizza crust a darker color. Bake temperatures range from 500°F (260°C) to 550°F (290°C).

Pan baking refers to pizza when baked in pans. Crust can be thick or thin and toppings range from light to heavy. Bake temperatures for pan baking range from 450°F (235°C) to 500°F (260°C).

4. RECOMMENDED OPERATING PROCEDURE

It is very important that at the end of each day's operation, the gas cock dial to the Main Burners is turned back to the Pilot position and that the Booster Burner switch is flipped to the "OFF" (O) position, leaving only the Pilot Burner on overnight. Keep the Pizza Push/Pull slides fully open.

Pre-heating:

- a) Turn the gas cock dial to the main burner to the "ON" position.
- b) Pre-heat the oven for 1 to 1 ½" hours at 50°F (30°C) lower than your baking temperature with Push/Pull slides fully open.

Baking:

- a) After pre-heating, raise the thermostat setting to your baking temperature.
- b) Light the Booster Burner and start baking.
- c) Check the bottom color of the Pie and close the Push/Pull slides partially (halfway) after the 4th or 5th bake to maintain the desired color.

When slow or idling, open the Push/Pull slides fully and set the thermostat at least 50°F (30°C) lower than your baking temperature in order to prevent the bake deck from getting too hot.

5. HELPFUL HINTS:

- a) An instructions plate is attached behind the damper knobs indicating how to set the oven for more top or more bottom heat. Opening the slides allows more heat to enter the baking chamber from the combustion / burner compartment. Closing the slides keeps more heat in the combustion / burner compartment, thereby making the bake deck hotter.
- b) If the oven is up to bake temperature but has not been used for a while, there is a tendency for the decks to get very hot. In this condition, when you put in one pizza, **TURN THE THERMOSTAT UP** so that the main burner flame is at its fullest, providing the extra heat needed to balance the high bottom heat. The thermostat should be turned down back to the normal setting, as soon as that pizza is baked.
- c) Frequently scrape and brush off decks to remove burnt residue which can cause an "off-flavour" and an increase in the bake time.
- d) Heavily topped pizza or pan pizza requires lower bake temperatures and longer bake times as compared to regular thin pizza with light toppings.
- e) Bubbles in fresh dough indicate an under-proofed or cold product. Allow the dough balls to proof to double in size and warm to room temperature before baking.
- f) Any type of pan or screen may be used in this oven. When choosing pans, be sure to pick a pan which is closest in height to that of your product.

Dark color Pans and Screens transfer heat better than light colored aluminum Pans or Screens. All Pans and Screens must be seasoned before use.

III. CLEANING and MAINTENANCE

THIS APPLIANCE MUST BE SERVICED ONLY BY AN AUTHORIZED SERVICE AGENT

Bakers Pride ovens are designed to be as maintenance-free as possible. Regular and thorough cleaning will help to keep the ovens operating properly. However, if service is required, contact an Authorized Service Agency or your Dealer.

Disconnect the power supply before cleaning or servicing the oven.

1. STAINLESS STEEL SURFACES:

- a) Deposits of baked-on splatter and grease, or discoloration, may be removed with the stainless cleaner sample supplied or by using any commercial cleaner recommended for stainless steel. Bakers Pride offers a stainless steel cleaner expressly made for this purpose. **RINSE WELL.**
- b) Apply a thin coat of oil to protect and enhance the finish.

NOTE: Apply stainless steel cleaner only when the oven is cold. Always rub with the grains while applying light pressure.

2. PAINTED SURFACES:

- a) Washing with mild soap and water solution is usually adequate to keep the outside clean.
- b) Apply a thin coat of oil to protect and enhance the finish.

3. DOOR MECHANISM:

Every six months (more frequently if the oven is used heavily) the bottom door spring mechanism and all moving parts must be inspected for wear.

Do not apply grease to spring lever shoulder bolt, spring roller or the door rod and the door pin. They have self-lubricating inserts that will be damaged when lubricated.

4. FLUE VENT:

The Ventilation System must be inspected every six months and maintained clean and free of obstructions.

5. OVEN INTERIOR:

Clean the oven interior only when the oven is cold. Use only the detergent solutions and cleaners that meet the national and/or local codes.

A. BAKING CHAMBER:

Clean the ceiling and the walls of the baking chamber with a mild soap and water solution. **Do not use oven cleaners, caustic solutions or mechanical means as this will damage the interior aluminized surfaces. Use caution when cleaning around the booster burner so as not to damage the ceramic igniter.**

B. BAKE DECKS:

The bake decks are heavy and fragile and they should be handled carefully.

The bake decks should be cleaned by using a long-handled scraper and a stiff wire brush. At the end of each day, turn the thermostat up to its maximum setting and let the oven sit at that temperature for at least ½ hour. This will burn off the food spilled onto the bake decks during the day's production and turn it into ash. This ash can be brushed off the next morning before turning the oven on. The bake decks should also be scraped and brushed during the day to help keep them clean. To remove excessive crumbs or carbon, the bake decks and the oven cavity may be vacuumed when the oven is cold. Do not use water or other liquids on the bake decks as this may cause them to crack. After long use, heavily soiled bake decks may be cleaned by turning them over, after they have been scraped down and brushed off. This will eventually burn off the heavily soiled side of the baking decks. This procedure may be repeated as needed.

C. BURNER COMPARTMENT:

Vacuum out any carbon or residue in the burner compartment and all around the bottom door. The holes and louvers on the outer surfaces of the oven must be kept free of obstructions to allow free movement of air for proper combustion and cooling of the controls.



BAKERS PRIDE LIMITED WARRANTY

30 Pine Street New Rochelle, New York 10801
914 / 576 - 0200 • US & Canada: 1 - 800 - 431 - 2745 • fax 914 / 576 - 0605

- WHAT IS COVERED** This warranty covers defects in material and workmanship under normal use, and applies only to the original purchaser providing that:
- ◆ The equipment has not been accidentally or intentionally damaged, altered or misused;
 - ◆ The equipment is properly installed, adjusted, operated and maintained in accordance with National and local codes, and in accordance with the installation instruction provided with the product;
 - ◆ The serial number rating plate affixed to the equipment has not been defaced or removed.
- WHO IS COVERED** This warranty is extended to the original purchaser and applies only to equipment purchased for use in the U.S.A.
- COVERAGE PERIOD** Cyclone Convection Ovens: BCO Models: One (1) Year limited parts and labor; (1) Year limited door warranty.
GDCCO Models: Two (2) Year limited parts and labor; (2) Year limited door warranty.
CO11 Models: Two (2) Year limited parts and labor; (5) Year limited door warranty.
All Other Products: One (1) Year limited parts and labor. Warranty period begins the date of dealer invoice to customer or ninety (90) days after shipment date from BAKERS PRIDE - whichever comes first.
- WARRANTY COVERAGE** This warranty covers on-site labor, parts and reasonable travel time and travel expenses of the authorized service representative up to (100) miles, round trip, and (2) hours travel time. The purchaser, however, shall be responsible for all expenses related to travel, including time, mileage and shipping expenses on smaller counter models that may be carried into a Factory Authorized Service Center, including the following models: PX-14, PX-16, P18, P22S, P24S, PD-4, PDC, WS Series and BK-18.
- EXCEPTIONS** All removable parts in BAKERS PRIDE Char-broilers, including but not limited to: Burners, Grates, Radiants, Stones and Valves, are covered for a period of SIX MONTHS.
All Ceramic Baking Decks are covered for a period of THREE MONTHS. The installation of these replacement decks is the responsibility of the purchaser.
The extended Cyclone door warranty years 3 through 5 is a parts only warranty and does not include labor, travel, mileage or any other charges.
- EXCLUSIONS**
- ◆ Negligence or acts of God,
 - ◆ Thermostat calibrations after (30) days from equipment installation date,
 - ◆ Air and Gas adjustments,
 - ◆ Light bulbs,
 - ◆ Glass doors and door adjustments,
 - ◆ Fuses,
 - ◆ Char-broiler work decks and cutting boards,
 - ◆ Tightening of conveyor chains,
 - ◆ Adjustments to burner flames and cleaning of pilot burners,
 - ◆ Tightening of screws or fasteners,
 - ◆ Failures caused by erratic voltages or gas supplies,
 - ◆ Unauthorized repair by anyone other than a BAKERS PRIDE Factory Authorized Service Center,
 - ◆ Damage in shipment,
 - ◆ Alteration, misuse or improper installation,
 - ◆ Thermostats and safety valves with broken capillary tubes,
 - ◆ Accessories — spatulas, forks, steak turners, grate lifters, oven brushes, scrapers, peels, etc.,
 - ◆ Freight — other than normal UPS charges,
 - ◆ Ordinary wear and tear.
- INSTALLATION** Leveling and installation of decks, as well as proper installation and check out of all new equipment — per appropriate installation and use materials — is the responsibility of the dealer or installer, not the manufacturer.
- REPLACEMENT PARTS** BAKERS PRIDE genuine Factory OEM parts receive a (90) day materials warranty effective from the date of installation by a BAKERS PRIDE Factory Authorized Service Center.

This Warranty is in lieu of all other warranties, expressed or implied, and all other obligations or liabilities on the manufacturers part. BAKERS PRIDE shall in no event be liable for any special, indirect or consequential damages, or in any event for damages in excess of the purchase price of the unit. The repair or replacement of proven defective parts shall constitute a fulfillment of all obligations under the terms of this warranty.

Form #U4177A 3/04



BAKERS PRIDE OVEN CO., INC.

30 Pine Street
New Rochelle, NY 10801

(914) 576-0200 Phone
(914) 576-0605 Fax

(800) 431-2745 US & Canada
www.bakerspride.com Web Address