





TECHNICAL SERVICE MANUAL



FLOOR MODEL GAS DECK OVENS:



SERIES 100, 200, 300, 400, 600, 800, 125, 805, 516, 616, 816

INTENDED FOR OTHER THAN HOUSEHOLD USE

OVEN MUST BE KEPT CLEAR OF COMBUSTIBLES AT ALL TIMES

 After the gas supply has been connected to your appliance, it is extremely important to check piping for possible leaks. To do this, use soap and water solution or solutions which are expressly made for this purpose. **DO NOT USE** matches, candles, flames or other sources of ignition since these methods are extremely dangerous. Post in a prominent location instructions to be followed in the event you smell gas. Obtain these instructions from your local gas supplier. 

 **For Your Safety:** Do not store or use flammable liquids or vapors in the vicinity of this or any other appliance. 

 **Warning:** Improper installation, adjustment, alteration, service or maintenance can cause property damage, injury or death. Read the Installation, Operating and Maintenance instructions thoroughly before installing or servicing this equipment. Initial heating of this oven may generate smoke or fumes and must be done in a well ventilated area. Overexposure to smoke or fumes may cause nausea or dizziness. 

NOTE: Only Pizza or Bread can have direct contact with ceramic decks. All other food products must be placed in a pan or container to avoid direct contact with ceramic decks.

This equipment has been engineered to provide you with year round dependable service when used according to the manufacturer's instructions and standard commercial kitchen practices.

BAKERS PRIDE OVEN CO., INC.

P/N U4154A 06/09

30 Pine Street
New Rochelle, NY 10801

+1 (914) 576-0200 Phone
+1 (914) 576-0605 Fax

(800) 431-2745 US & Canada
www.bakerspride.com Web Address
info@bakerspride.com

Continuous improvement is a Bakers Pride tradition. All efforts have been taken to insure this booklet is up to date as of the day it is printed. In case of discrepancies or uncertainties, please consult with your Technical Service Technician.

TABLE OF CONTENTS

Table of Contents	3
Dimensions and Specifications	4
Gas Ratings	8
Installation	9
Receiving	9
Mount The Legs	10
Optional Casters	10
Deck Installation	10
Ceiling Tiles	11
Gas Connections	12
Ventillation	13
Flame and Burner Adjustments	14
Gas Pressure Adjustments	14
Pilot Lighting and Adjustments	14
Flame and Air Mixture Adjustments	15
By-Pass Flame Adjustments	16
Automatic Timer	16
Il Forno Booster Burner	17
Il Forno Wire Diagram	18
Gas Conversion	19
Troubleshooting	20
Temperature Calibration	22
Test Thermopile and Gas Valve	22
Warranty	23

DIMENSIONS AND SPECIFICATIONS

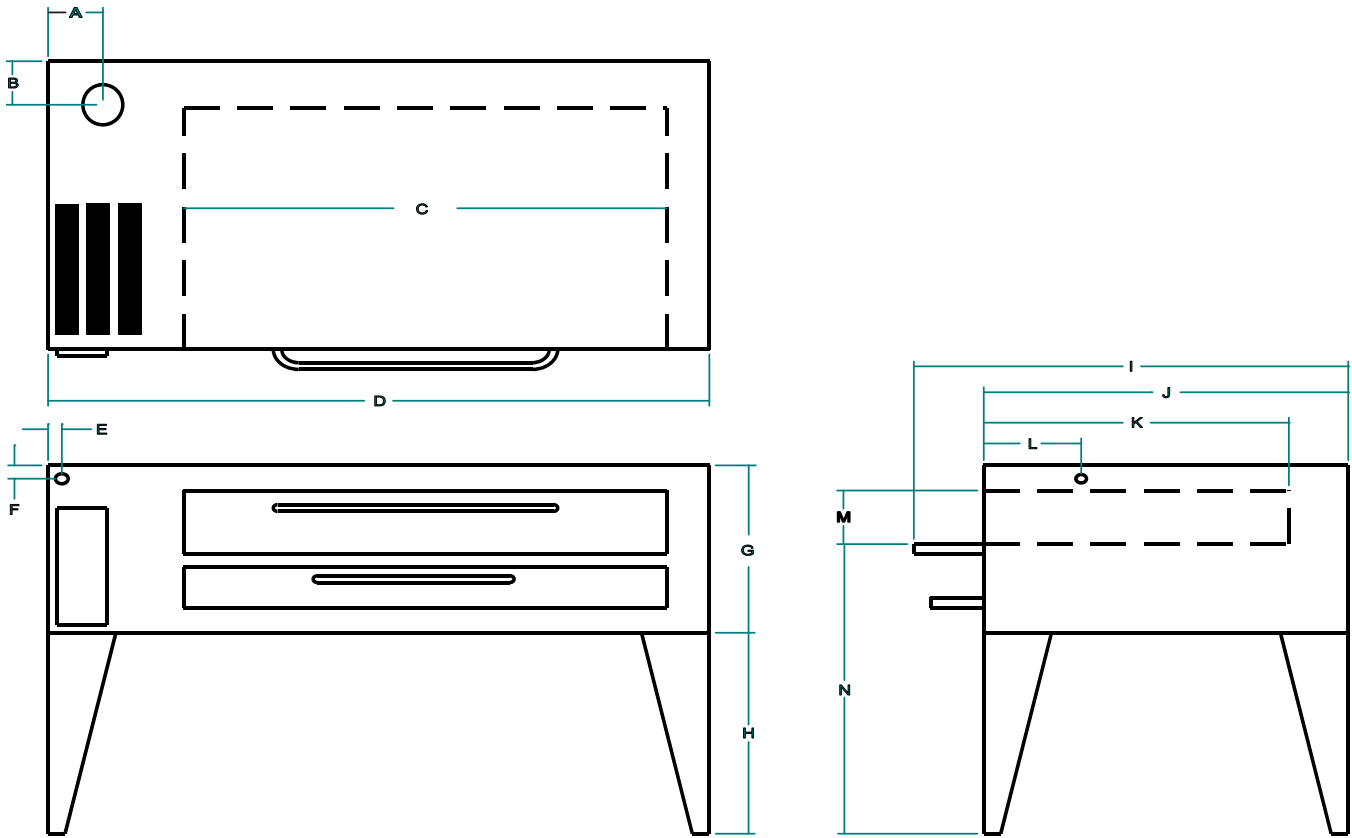

Nominal dimensions in inches on standard legs. Refer to individual spec sheets for latest information.

Model	A	B	C	D	E	F	G	H	I	J	K	L	M	N
Y600	6 1/2	6 1/2	60	78	1 5/8	1 3/4	25	30	51	43	36	11 1/2	8	43
Y800	6 1/2	6 1/2	66	84	1 5/8	1 3/4	25	30	59	51	44	11 1/2	8	43
D125	6 3/8	8 3/8	48	65	1 5/8	2 3/4	29	30	54	43	36	11 1/2	10	44
DS805	6 1/2	8 1/4	48	55	1 5/8	2 3/4	25	30	49	43	36	11 1/2	6 3/4	45
GS805	6 1/2	8 1/4	36	53	1 5/8	2 3/4	25	30	49	43	36	11 1/2	6 3/4	45
151	4 3/4	8	36	48	1 1/8	1 3/4	24	30	51	33	34 1/2	11 1/4	8	43
251	4 3/4	8	36	48	1 1/8	1 3/4	24	30	51	43	34 1/2	11 1/4	8	43
351	4 3/4	8	45	57	1 1/8	1 3/4	24	30	51	43	34 1/2	11 1/4	8	43
451	4 3/4	8	45	66	1 1/8	1 3/4	24	30	51	43	34 1/2	11 1/4	8	43
3151	4 3/4	8	54	57	1 1/8	1 3/4	24	30	51	33	34 1/2	11 1/4	8	43
4151	4 3/4	8	54	66	1 1/8	1 3/4	24	30	51	33	34 1/2	11 1/4	8	43

DIMENSIONS AND SPECIFICATIONS

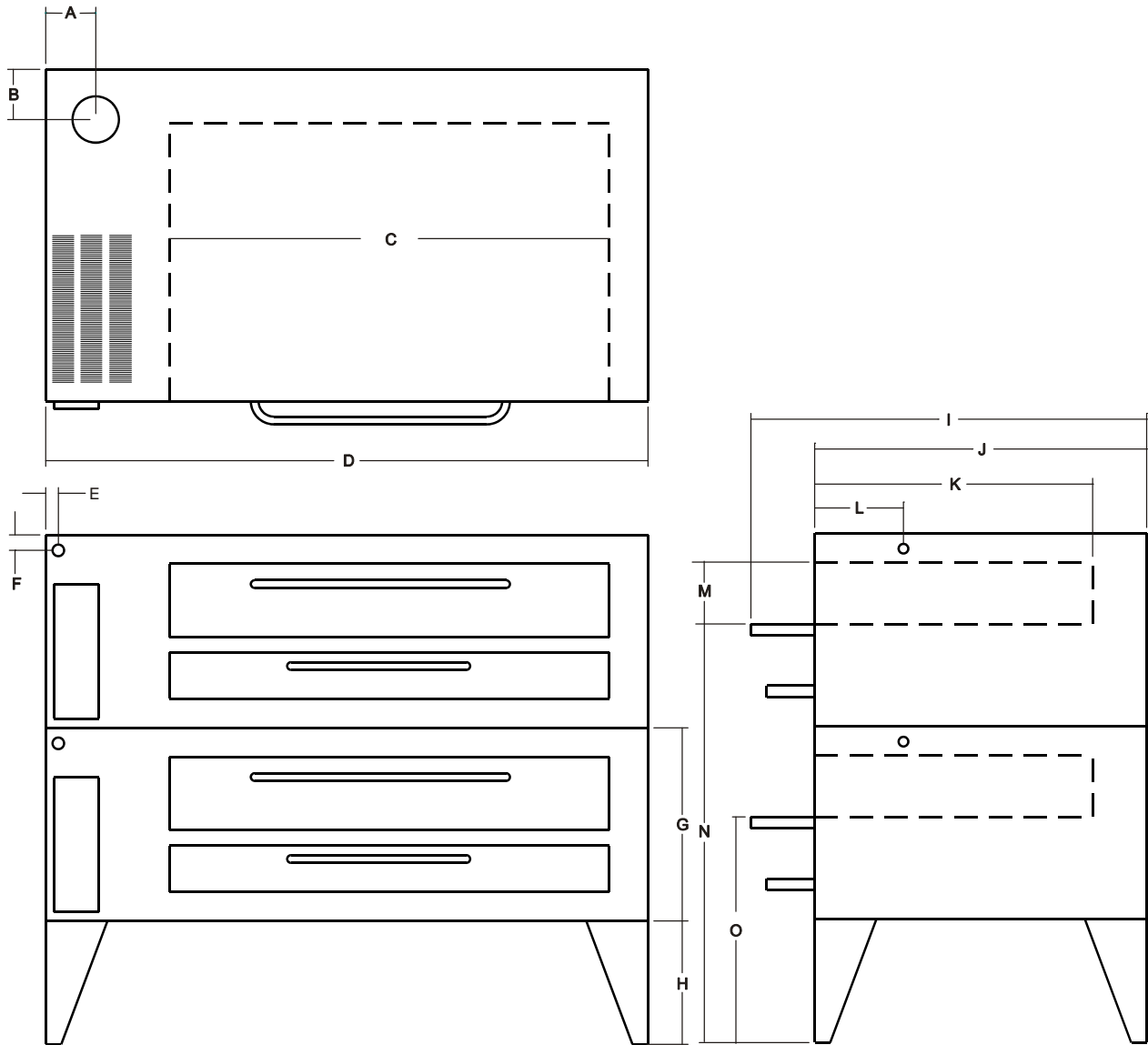

Nominal dimensions in inches on standard legs. Refer to individual spec sheets for latest information.

Model	A	B	C	D	E	F	G	H	I	J	K	L	M	N	O
Y602	6 1/2	6 1/2	60	78	1 5/8	1 3/4	25	16	51	43	36	11 1/2	8	54 1/2	29 1/4
Y802	6 1/2	6 1/2	66	84	1 5/8	1 3/4	25	16	59	51	44	11 1/2	8	54 1/2	29 1/4
D250	6 3/8	8 3/8	48	65	1 5/8	2 3/4	29	12	54	43	36	11 1/2	10	55	26 1/4
DS990	6 1/2	8 1/4	48	55	1 5/8	2 3/4	25	16	49	43	36	11 1/2	6 3/4	54 3/4	30
GS990	6 1/2	8 1/4	36	53	1 5/8	2 3/4	25	16	49	43	36	11 1/2	6 3/4	54 3/4	30
152	4 3/4	8	36	48	1 1/8	1 3/4	24	16	51	33	34 1/2	11 1/4	8	52 3/4	28 3/4
252	4 3/4	8	36	48	1 1/8	1 3/4	24	16	51	43	34 1/2	11 1/4	8	52 3/4	28 3/4
352	4 3/4	8	45	57	1 1/8	1 3/4	24	16	51	43	34 1/2	11 1/4	8	52 3/4	28 3/4
452	4 3/4	8	45	66	1 1/8	1 3/4	24	16	51	43	34 1/2	11 1/4	8	52 3/4	28 3/4
3152	4 3/4	8	54	57	1 1/8	1 3/4	24	16	51	33	34 1/2	11 1/4	8	52 3/4	28 3/4
4152	4 3/4	8	54	66	1 1/8	1 3/4	24	16	51	33	34 1/2	11 1/4	8	52 3/4	28 3/4

DIMENSIONS AND SPECIFICATIONS

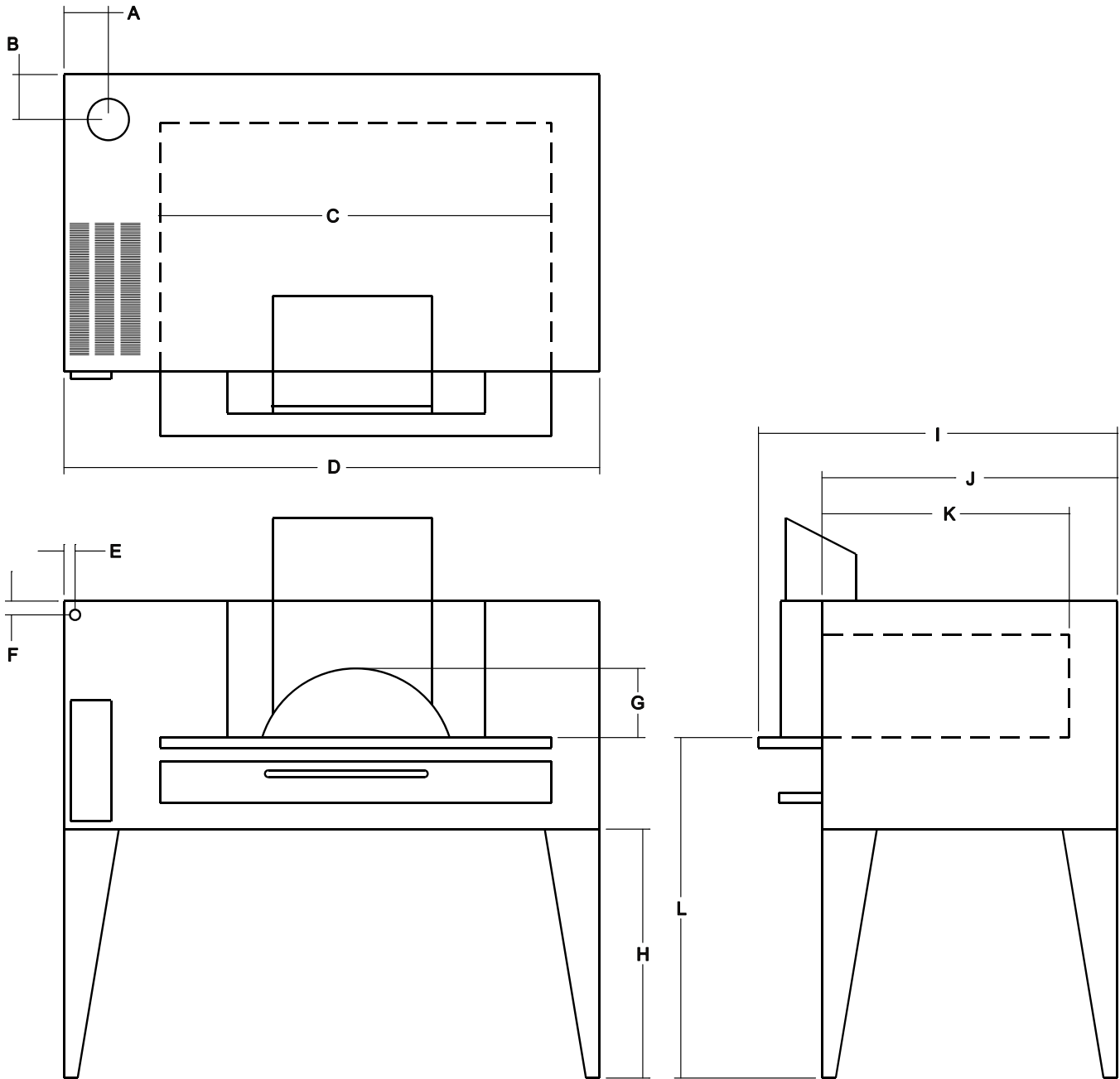

Nominal dimensions in inches on standard legs. Refer to individual spec sheets for latest information.

Model	A	B	C	D	E	F	G	H	I	J	K	L
FC516	6 3/8	8 3/8	48	65	1 5/8	1 3/4	10	36	52	43	36	49 1/4
FC616	6 1/2	6 1/2	60	78	1 5/8	1 3/4	10	36	52	43	36	49 1/4
FC816	6 1/2	6 1/2	66	84	1 5/8	2 3/4	10	36	60	51	44	49 1/4

DIMENSIONS AND SPECIFICATIONS

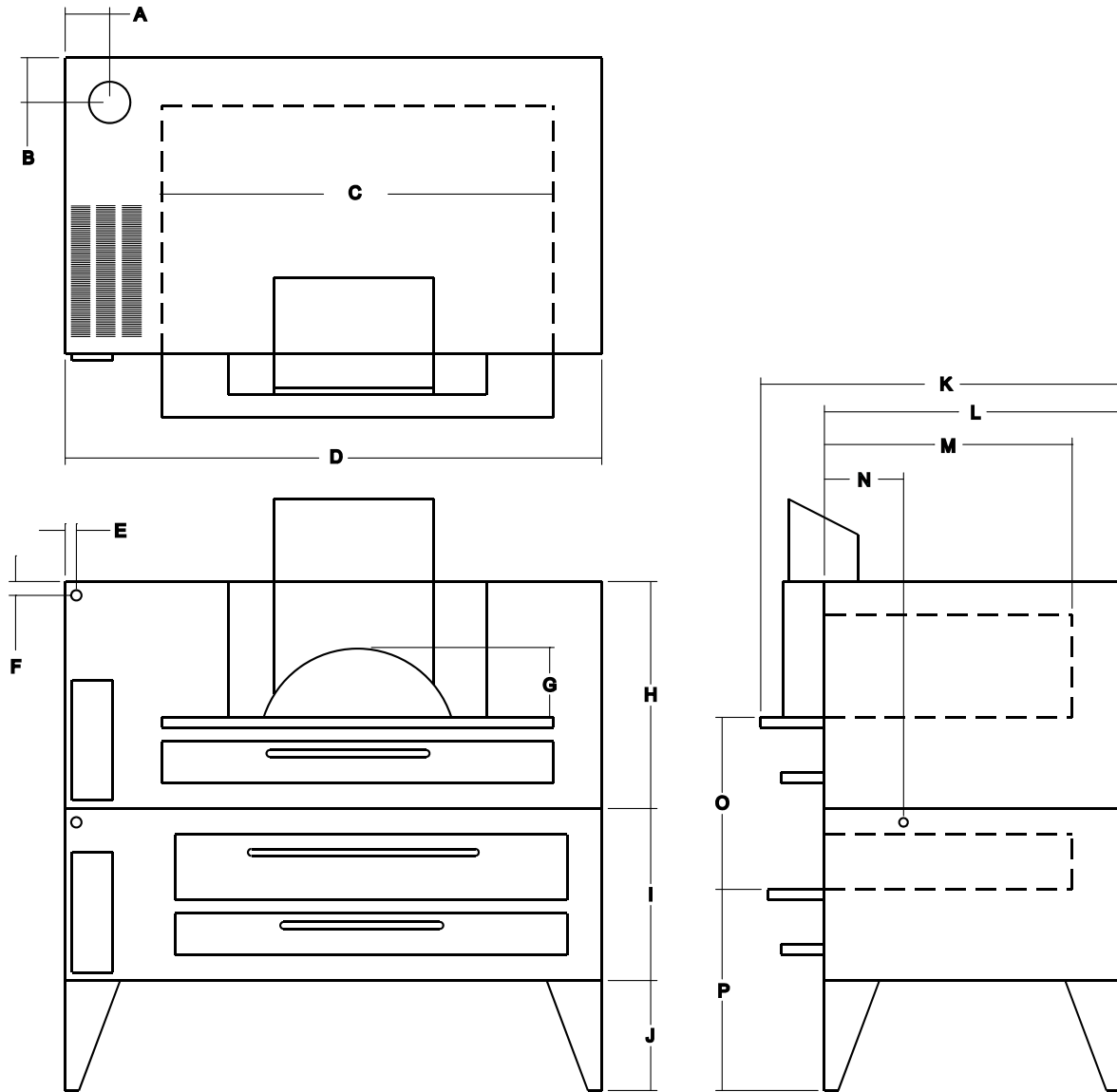

Nominal dimensions in inches on standard legs. Refer to individual spec sheets for latest information.

Model	A	B	C	D	E	F	G	H	I	J	K	L	M	N	O	P
FD516	6 3/8	8 3/8	48	65	1 5/8	1 3/4	10	33	29	12	54	43	36	11 1/2	28 5/8	26 1/8
FY616	6 1/2	6 1/2	60	78	1 5/8	1 3/4	10	33	25	16	51	43	36	11 1/2	25	29 3/4
FY816	6 1/2	6 1/2	66	84	1 5/8	2 3/4	10	33	25	16	59	51	44	11 1/2	25	29 3/4

GAS RATINGS

NORTH AMERICAN GAS RATINGS						
	NATURAL			PROPANE		
	BTU	KW	PRESSURE	BTU	KW	PRESSURE
Y600	120,000	35.15	3.5 wc	120,000	35.15	10 wc
Y800	120,000	35.15	3.5 wc	120,000	35.15	10 wc
D125	125,000	36.6	3.5 wc	105,000	30.7	10 wc
DS805	70,000	21	3.5 wc	70,000	21	10 wc
GS805	60,000	18	3.5 wc	60,000	18	10 wc
151	48,000	14	3.5 wc	48,000	14	10 wc
251	60,000	18	3.5 wc	60,000	18	10 wc
351	70,000	21	3.5 wc	70,000	21	10 wc
451	80,000	24	3.5 wc	80,000	24	10 wc
3151	70,000	21	3.5 wc	70,000	21	10 wc
4151	70,000	21	3.5 wc	70,000	21	10 wc
FC516	140,000	41	3.5 wc	140,000	41	10 wc
FC616	140,000	41	3.5 wc	140,000	41	10 wc
FC816	140,000	41	3.5 wc	140,000	41	10 wc

EUROPEAN GAS RATINGS															
EN 437	GAS AND PRESSURE	DESIGNATED COUNTRY													
		AT	BE	DK	FI	FR	DE	IE	IT	LU	NL	PT	ES	SE	GB
I₂H	G20@20 mbar	◆		◆	◆			◆	◆			◆	◆	◆	◆
I₂L	G25@25 mbar										◆				
I₂E	G20@20mbar						◆			◆					
I₂E+	G20/25@20/25mbar		◆			◆									

INSTALLATION

RECEIVING

Check the package for damage. If any damage is visible you should mark the bill of lading you sign that there may be concealed damage. Insure the container is upright. If the container is not upright major damage can occur to your appliance. If damage is discovered, do not refuse delivery. Contact the carrier and file appropriate freight claims. Do not contact the manufacturer. Shipping damage claims are to be resolved between the customer, shipping carrier and dealer. The manufacturer may assist in resolving any such claims, but such assistance does not relieve you of your responsibility.

Read the notice on the outside carton regarding damage in transit. Damage discovered after opening the shipping container and inspecting the oven is "CONCEALED DAMAGE" and the carrier must be notified immediately to send an inspector and also to furnish forms for the customer's claim.

When the oven arrives it should consist of:

- a. A crate or carton containing your new oven
- b. A carton containing four legs with mounting hardware
- c. A strapped skid containing baking decks and (if ordered) ceiling tiles

Place the oven and parts as close to the final installation area as possible. Your oven is normally packed on its side or back. Leave it in this position while unpacking. The skid may be left in place during unpacking and may be convenient in further handling. Unpack your oven carefully to avoid damage. If concealed damage is found refer to the instructions above.

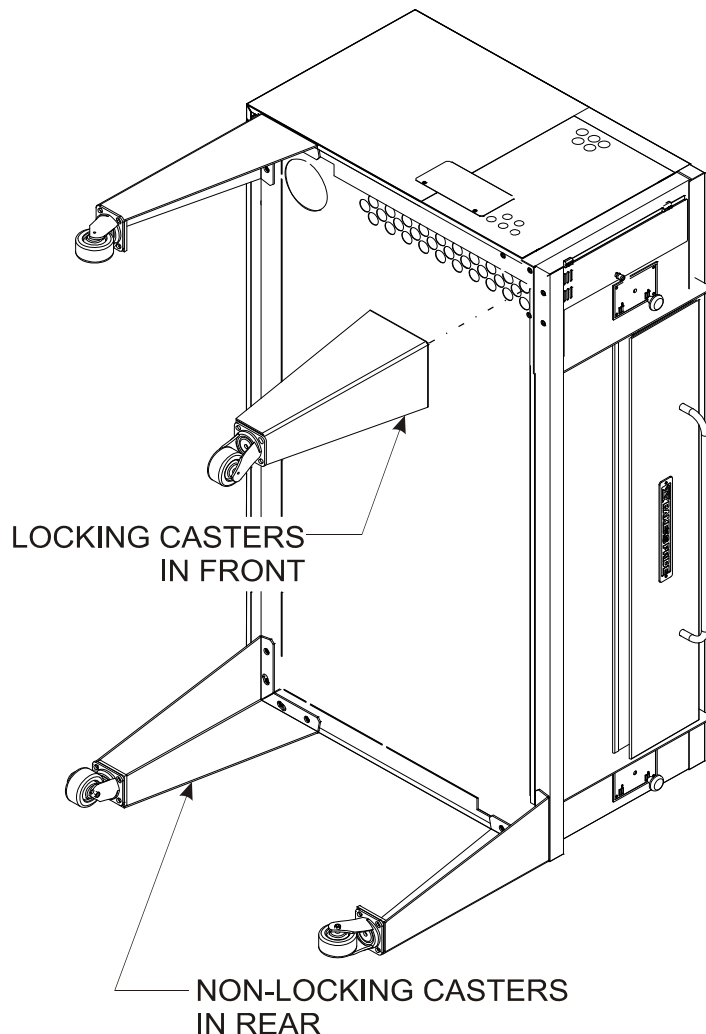

INSTALLATION

MOUNT THE LEGS

Use proper lifting equipment. Due to the oven's size and weight a rolling lift jack, air sled or pallette jack may be required.

Legs are shipped in a separate container with mounting hardware.

Bolt two legs to the upper corners of the oven. Tighten in place.

Use proper lifting equipment. Lower the oven down so that the two bolted legs rest on the floor.

Use proper lifting equipment. Raise the second end of the oven slightly higher than the height of the legs. Remove the skid and support the frame of the oven.

Mount the remaining two legs and bolt in place.

Use proper lifting equipment. Lift oven and remove all supports. Move oven into its final location.

OPTIONAL CASTERS

When optional casters are ordered there will be two with locks and two without locks.

Locking casters to be mounted at the two front corners of the oven.

Appliances mounted on casters must be connected to the building framing to prevent stress on electrical and gas connections.

NOTE: Installation should be made with a connector that complies with the latest edition of the Standard for Connectors for Movable Gas Appliances ANSI Z21.69 in the USA and CAN CGA-6.16 in Canada and a quick disconnect device that complies with the latest edition of the Standard for Quick Disconnect Devices for use with gas fuel ANSI Z21.41 in the USA and CAN CGA 1-6.9 in Canada an adequate means must be provided to limit the movement of the appliance without depending on the connector and any quick disconnect device or its associated piping. The restraint should be attached to the rear legs of the oven on which casters are mounted. If disconnection of the restraint is required for service the restraint must be reconnected after the appliance is returned to its normally installed position.

Minimum Clearances:

Left Side from Combustible construction: 3" [75 mm] from Non-Combustible construction: 0

Right Side from Combustible construction: 1" [25 mm] from Non-Combustible construction: 0

Rear from Combustible construction: 3" [75 mm] from Non-Combustible construction: 2" [50 mm]

DECK INSTALLATION

Remove all packing material, samples, shims, etc. from the baking chamber leaving the metal hearth sheets on the baking chamber floor. Make sure the sheets are arranged to cover the whole bottom of the chamber.

Depending on the model, two, three, or four baking hearth stones are required for the cooking deck.

The hearth stones are heavy and fragile. Careful handling is required for personal safety and to insure proper performance.

Slide the first stone into the baking chamber. Push it as far back as possible. Push it to one side as far as possible.

Slide additional stones into the baking chamber similarly. If more than two stones are required for the oven cavity install the side stones first to insure they are properly positioned into the cavity corners behind the door frame as required.

Seams should be closed tightly by moving hearth stones against each other.

Use of metal shims may be required to level the stones.

The use of steel wedges between the hearth stones and cavity sides may be required. Care must be exercised if wedges are installed along side walls of the cavity to insure the operation of the vent slides is not adversely affected by too much side pressure causing them to bind.

INSTALLATION

On models that include them install the hearth trim strip between the front of the baking hearth stones and the door frame.

After curing and use, new stones may require re-leveling. This is the responsibility of the owner and not the manufacturer.

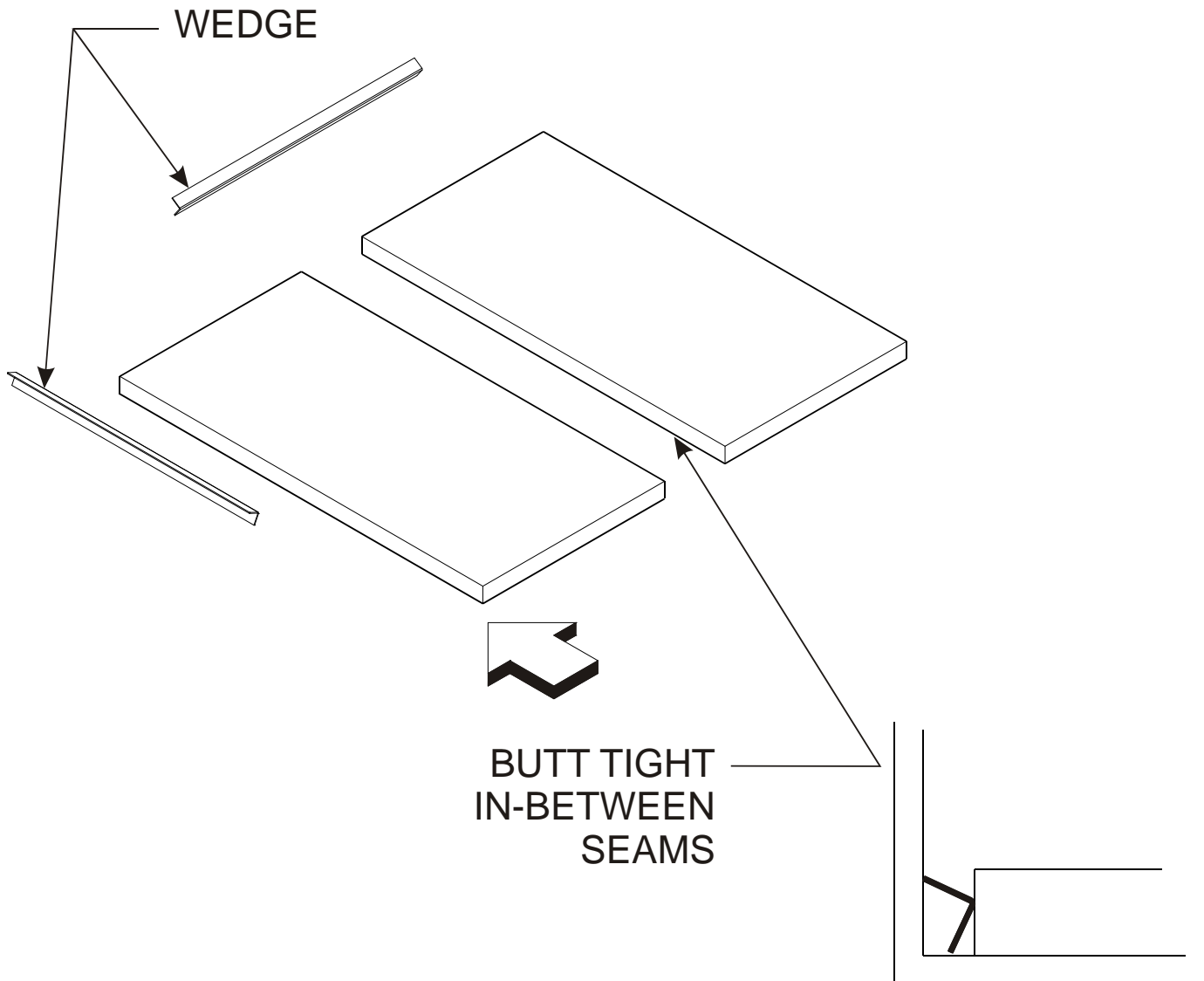

CEILING TILES

Some models have the option of having a hearth lined ceiling. These tiles will be packed separately from the oven, may be in the same container as the baking deck tiles.

For Il Forno models there are multiple square tiles that get installed into the top supports by tipping at an angle, inserting the edge above the support rail toward the center, setting one edge along the support rail along the side of the cavity and letting the tipped up edge come down to rest on the center support rail. Center tiles are installed the same way.

For deck ovens a long narrow ceiling stone will be inserted at a cut-out in the front edge along the door opening. Set the rear end up over the ledge along the back of the cavity. Swing the front edge up through the cut-out and slide it to the left or right for positioning.

INSTALLATION

GAS CONNECTIONS

Your oven installation must conform to local codes. In the absence of local codes it must comply with National Codes.

The type of gas the oven is equipped for is stamped on the rating plate. Connect ovens marked “NAT” only to natural gas supplies. Connect ovens marked “LP” only to propane gas supplies.

Before connecting oven the gas supply should be inspected by your gas supplier or local authorities to insure sufficient gas flow, pressure and meter size.

If the gas supply line is greater than 1/2 PSI [3.45 kPa] a step-down regulator is required.

The gas inlet connection for all ovens is 3/4” NPT.

Each oven deck requires its own gas shut-off that is end-user supplied.

All pipe joints must be sealed with pipe thread sealant rated for use with LP gas supplies.

Before use all pipe joints must be inspected for leaks. Use a soap and water solution or a product expressly made for this purpose. Do NOT use matches, candles or flames to check for leaks as these methods are extremely dangerous.

The oven and its shut-off valve must be disconnected from the gas supply piping during any pressure testing in excess of 1/2 PSI [3.45 kPa].

The oven must be isolated from the gas supply by manual shut-off valve during any pressure testing at levels equal or less than 1/2 PSI [3.45 kPa].

Only Natural Gas equipped models are available in European Community Countries

In MASSACHUSETTS all gas products must be installed by a Massachusetts licensed plumber or gas fitter. Ventilation hoods must be installed in accordance with NFPA-96, current edition, with interlocks as described in that standard.



WARNING: Installation must conform with local codes and/or with the latest edition of the National Fuel Code ANSI Z223.1 Natural Gas Installation code in the USA or CAN/CGA-B149.1 or the Propane Installation code, CAN/CGA-B 149.2 in Canada.



WARNING: This appliance must be installed by a competent person in accordance with rules in force. In the U.K. Corgi registered installers (including the regions of British Gas) undertake to work to safe and satisfactory standards. This appliance must be installed in accordance with the current Gas Safety (Installation and Use) Regulations and the relevant Building Regulations/IEE Regulations. Detailed recommendations are contained in the British Standard Codes of Practice BS 6172, BS 5440: Part 2 and BS 6891.



INSTALLATION

VENTILLATION

All gas appliances must be ventilated. Proper air supply and ventilation is essential for personal safety and proper operation. Improper ventillation can also cause poor baking results. Consult NPFA 96 as well as local codes regarding ventilation requirements.

Ventilation is the requirement of the end user and you are strongly recommended to use an HVAC specialist to design a proper system for your kitchen.

Traditional installations will be under a canopy hood. This hood should be a minimum of 78 in [1950 mm] from the floor and extend beyond the footprint of the oven by 4" - 6" [100 mm - 150mm] on all sides. The flue diverter included with your oven should be used.

For many installations a direct vent option is an option. A draft hood connected to your oven flue exit is necessary. This piping should go vertical and never slant downwards. Termination of the vent must conform to standards.

Direct venting is not available for installations within European Community Countries.

Direct venting is not an option for Il Forno ovens.

Il Forno ovens, singly or stacked, may be vented with an optional Eye Brow Hood. Eye Brow hoods are shipped separately for installation before first use. A separately sized and designed exhaust fan system must also be installed.

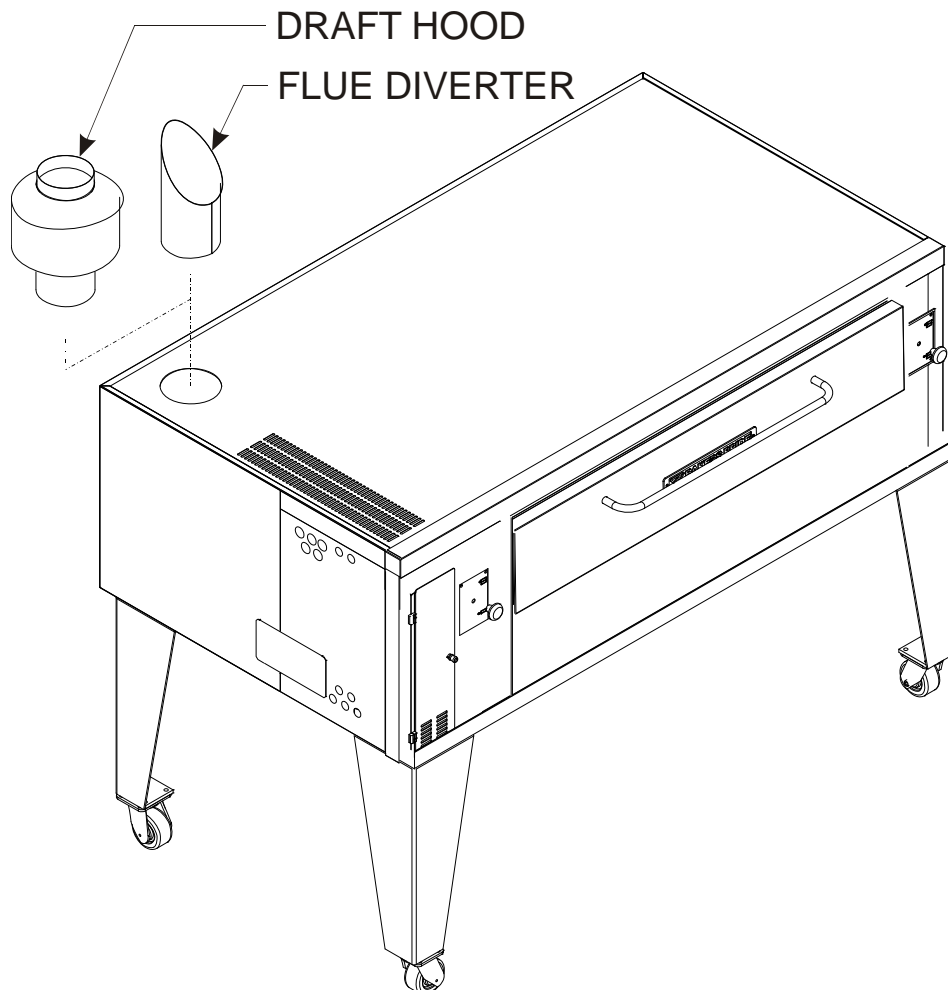

FLAME AND BURNER ADJUSTMENTS

GAS PRESSURE ADJUSTMENTS

Baker's Pride ovens are equipped with fixed sized orifices. Adjustments can not be made to the orifice.

Gas flow and pressure is to be checked at installation.

A pressure tap is supplied with each oven. It is located in the control compartment along the gas supply piping. On older models this tap will be along the manifold pipe or fittings. On newer models the pressure tap will be located between the gas valve and thermostat.

Gas supply pressure must match the oven's rating plate. This value must be checked with the oven and all other appliances on the same gas supply line running at their highest burner setting.

Connect a manometer to the pressure tap and check the gas pressure while the burners are running at their highest setting. Ovens equipped with a 7000 combination

valve have an adjustment screw on the front of the valve. Ovens equipped with a pilot safety valve will have a traditional regulator in the gas line before the valve.

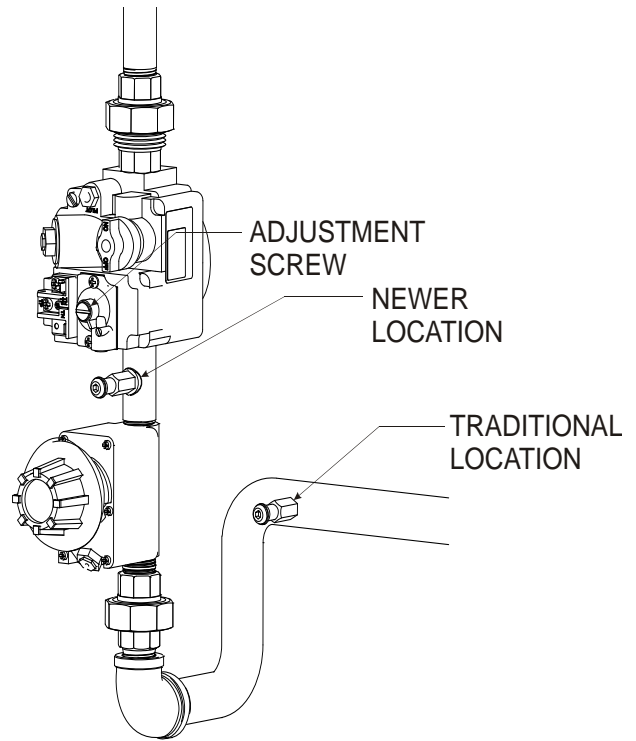

This adjustment is originally made at the factory prior to shipment. However, it must be re-checked and/or adjusted at installation to match your gas supply. This adjustment is not covered by warranty.

PILOT LIGHTING AND ADJUSTMENTS

Most ovens have a combination valve that supplies gas to the pilot burner. Some ovens have a pilot safety valve. The basic method is the same for each.

The 7000 combination valve has a dial that controls the gas flow. Turn it to "PILOT". The pilot safety valve has a RED button.

Turn the gas supply to the oven ON.

Slightly depress and turn the combination gas cock knob to the PILOT position.

Depress the dial or the red button and hold. It may take several minutes to bleed air from the tubing supplying gas to the pilot burner.

Apply a flame to the pilot burner to light. Continue to hold the dial/button depressed for at least 30 seconds for the flame to be sensed by the valve.

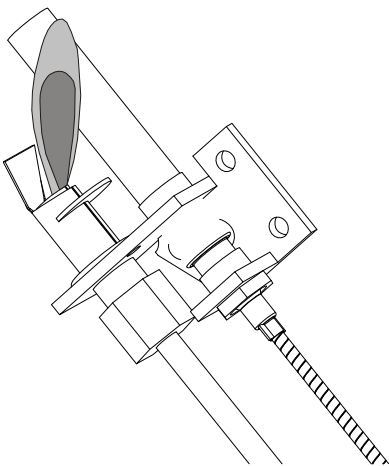

After letting go of the dial/button if the pilot flame goes out repeat the above steps.

Once the flame is lit and burning normally for several minutes to insure all air is bled from the supply tube the flame may need to be adjusted.

On pilot safety valves there is an adjustment screw above the red button. On combination valves there is an adjustment screw at the top left corner of the valve body. Remove the pilot adjustment cap.

Using a small flat blade screwdriver turn the screw counter-clockwise to reduce the size of the flame. Turn the screw clockwise to increase the size of the flame. The flame should be approximately 3/8 in to 1/2 in high and wrap around the flame sensor bulb.

FLAME AND BURNER ADJUSTMENTS

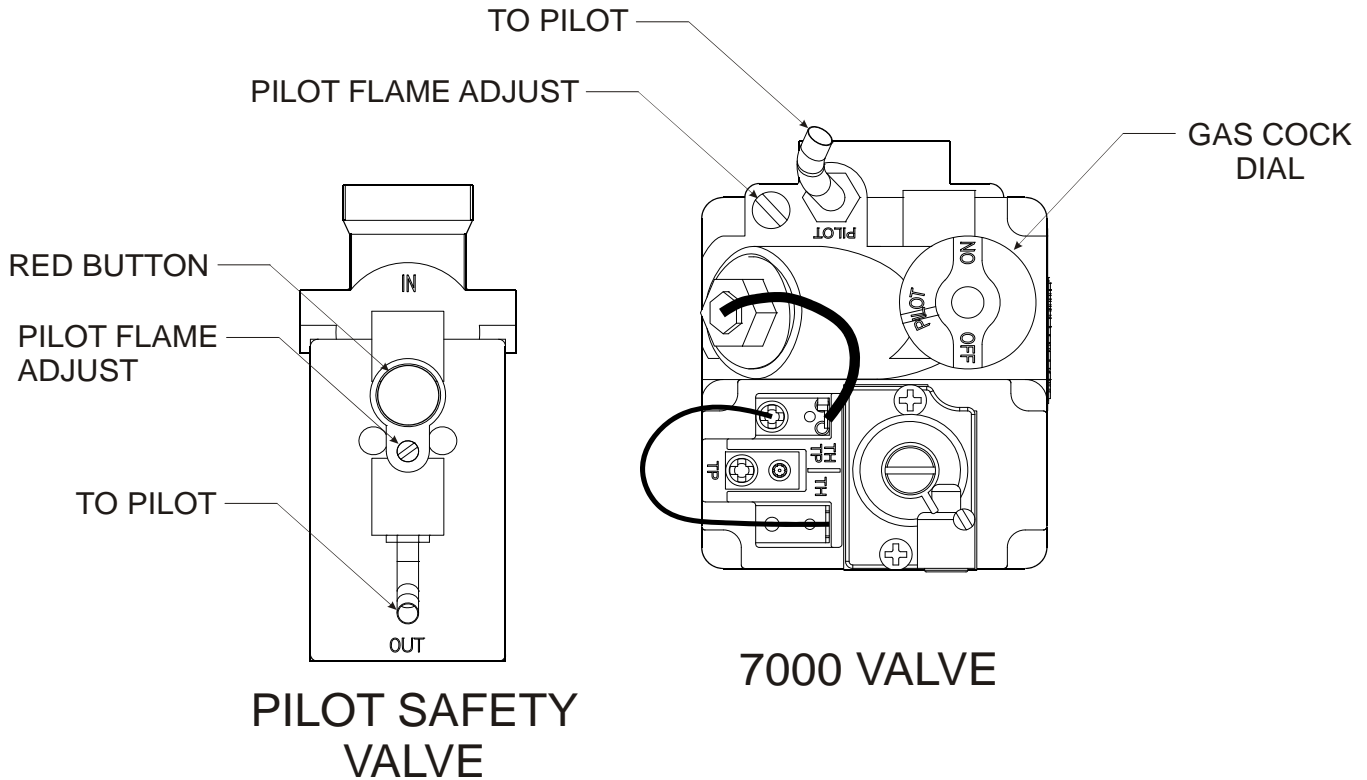

FLAME AND AIR MIXTURE ADJUSTMENTS

Light the burners and turn the thermostat dial to the desired temperature setting. Allow the flame to burn for a few minutes to settle.

Observe the burner flame. The flame should be sharply formed cone shapes that are blue in color. If your fuel source is propane there may be yellow tips that flicker briefly.

If the flame is not formed, is lazy, and has a lot of yellow color, not enough air is mixing with the gas. If the flame “roars” and you can see the base of the flame separating from the burner pipe— lifting, there is too much air mixing with the gas. For either condition the air/fuel mixture must be adjusted.

- A. Loosen the locking disk.
- B. Turn the larger adjusting disk towards the gas/air port of the inspirator to reduce the opening to reduce the air. The flame will turn lazy and yellow in color.
- C. Gradually turn the adjusting disk away from the gas/air port to increase the opening and thus increase the air. The flame shape will become more cone shaped and the yellow color will disappear.
- D. Observe the flame for a minute to insure the setting does not have be adjusted more. Tighten the locking ring against the adjustment disk.

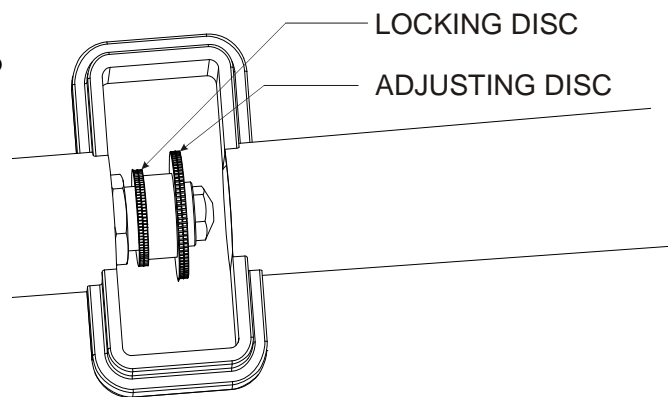

This adjustment is originally made at the factory prior to shipment. However, it must be re-checked and/or adjusted at installation to match your gas supply. It may also need to be periodically adjusted during the life of your oven, especially if the fuel source is propane. This adjustment is not covered by warranty.

FLAME AND BURNER ADJUSTMENTS

BY-PASS FLAME ADJUSTMENT

Your oven is equipped with a throttle back thermostat that continually maintains a small flame to help reduce temperature swings as the burners cycle on and off. When the oven reaches set temperature the thermostat main valve closes and only gas from the by-pass valve flows to the burners.

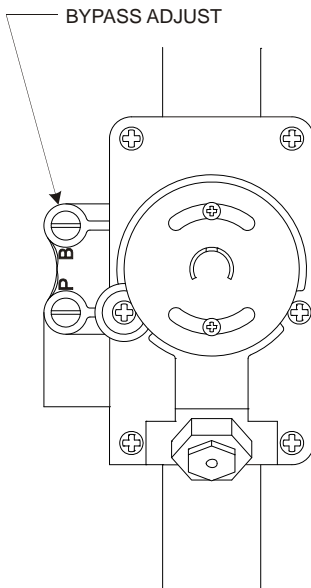

Turn the temperature dial to 300 °.

After the oven temperature rises and remains constant turn the dial back down to the lowest setting.

This closes the main valve.

Remove the knob by pulling straight from the thermostat body.

Refer to the figure showing a thermostat with knob removed.

There are two adjustment screws on the left side of the thermostat body. The upper screw has a "B" marking along side. Using a small flat blade screw-driver turn the screw to adjust the by-pass flame.

Turn the screw counter-clockwise to increase the flame height. Turn the screw clockwise to reduce the flame height.

When properly set there should be a minimal height flame that maintains itself along the burners.

Replace the dial. Turn the temperature up and down several times to insure the by-pass flame maintains at a minimal setting.

This adjustment is made at the factory prior to shipment. However, it must be re-checked and/or adjusted at installation. This adjustment is not covered by warranty.

AUTOMATIC TIMER

When ordered the automatic oven start timer will turn the main burner on at the set time of your choosing.

The thermostat jumper between the TH-TP and TH contacts on the 7000 combination gas valve are replaced by wire leads to the switch contacts of the timer. The red and white leads from the Thermopile must be connected. The main burner will not turn on unless the pilot is lit.

NO VOLTAGE IS TO BE CONNECTED TO THESE CONTACTS. This connection is an extension of the jumper which tells the valve open the main gas valve. At the appointed time the clock closes the switch terminals and completes the circuit. The valve interprets this as a call for heat and opens the main gas valve.

The main burner may be lit manually by opening the switch box and turning the timer switch to the "ON" position.

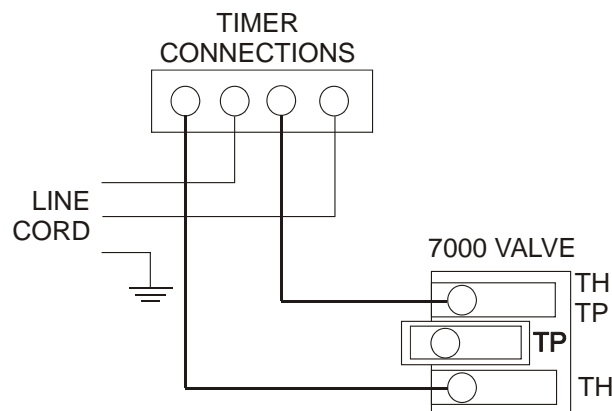

IL FORNO BOOSTER BURNER

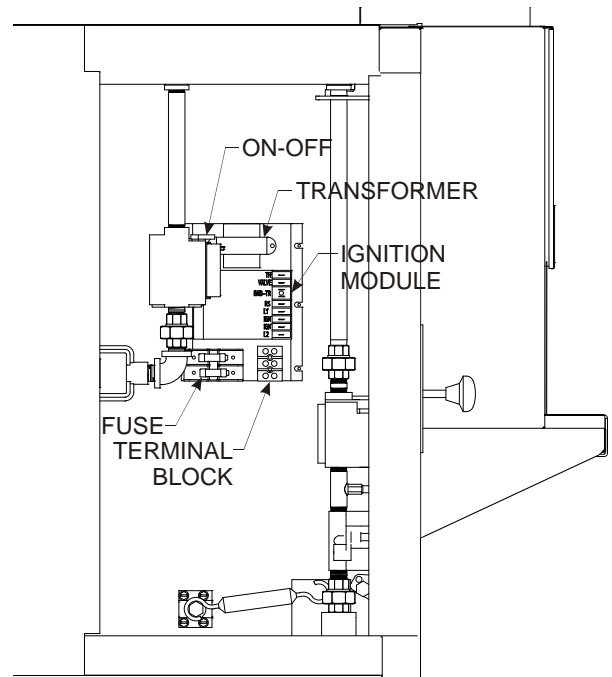
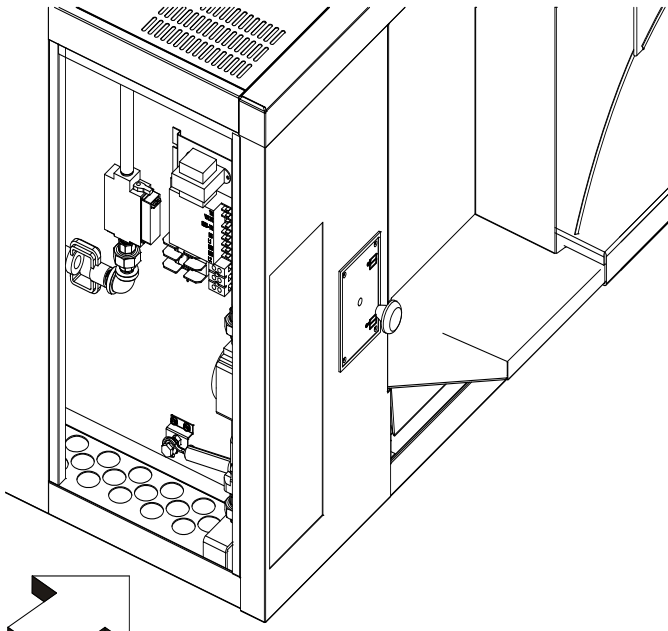

The Il Forno booster burner is located in the center rear of the oven cavity visible through the front opening as an added visual effect. It also provides 20 KBTU additional heat to the oven.

Controls for this feature are in the left side compartment behind the typical gas control stack. The booster burner is plumbed and controlled separately from the main burner. There is an ON-OFF switch just inside the control compartment door. There is an ON-OFF switch on the gas valve.

When turned on the ignition module energizes the hot surface ignitor. When the hot surface ignitor reaches current a signal opens the gas valve for the burner. The flame sensor completes the circuit when it signals the ignition module it is sensing flame. This burner has its own inspirator and it typically adjusted to provide a YELLOW flame to simulate wood burning at the back of the cavity.

OLDER MOUNTING

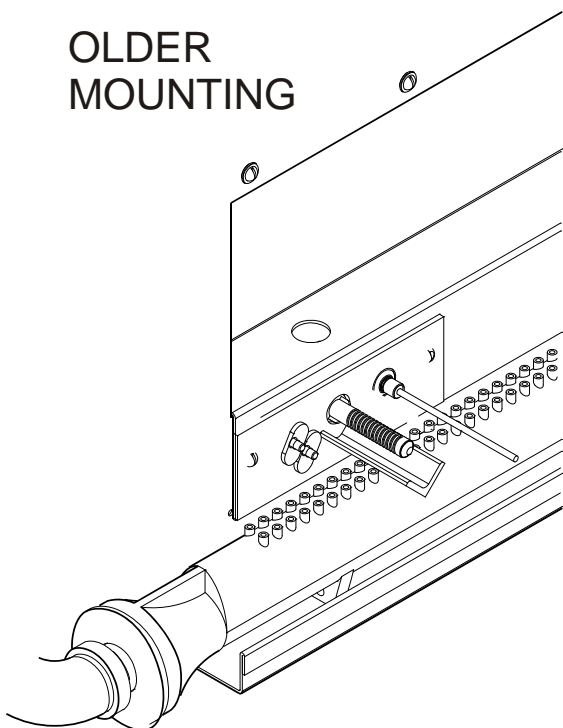

NEWER MOUNTING

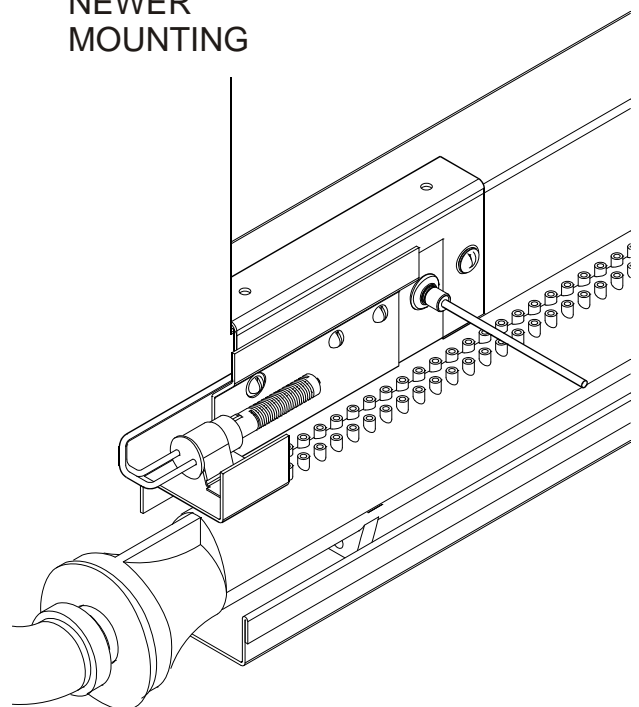

IL FORNO WIRE DIAGRAM

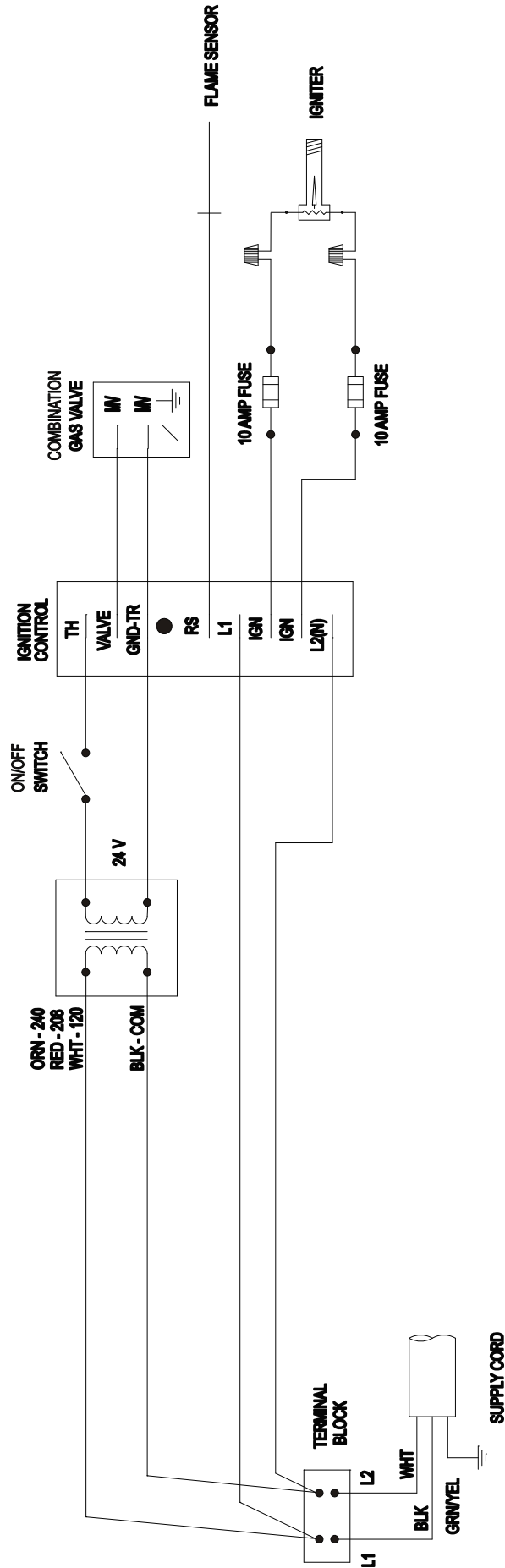

GAS CONVERSION

WARNING

Conversion kits shall be installed by a qualified service agency in accordance with the manufacturer's instructions and all applicable codes and requirements of the authority having jurisdiction. If the information in these instructions is not followed exactly, a fire, an explosion or production of carbon monoxide may result causing property damage, personal injury or loss of life. The qualified service agency is responsible for the proper installation of this kit. The installation is not proper and complete until the operation of the converted appliance is checked as specified in the manufacturer's instructions.

There are times it is required to do a field conversion from one gas type to another.

Consult with your Technical Service Representative to order the correct parts for the oven model you will be converting.

- ◆ Shut off the gas to the oven.
- ◆ Remove the two screws that hold the regulator in place on the combination valve. Remove the gasket. Install a new gasket and the new regulator. Insure the regulator gasket is in place with two circular cut-outs over small posts in the valve body casting. Evenly tighten the two screws holding the regulator in place. The conversion kit includes a label to be placed on the side of the valve body to inform others that the conversion has taken place.
- ◆ Remove the orifices from the inspirators. Depending on the oven model there will be one, two or three that need to be changed.
- ◆ Change the orifice in the pilot.
- ◆ Refer to other sections of this manual. Test for gas leaks.
- ◆ Follow normal start-up procedures for lighting and adjusting the pilot and insuring the gas-air mixture to the burners is correct.

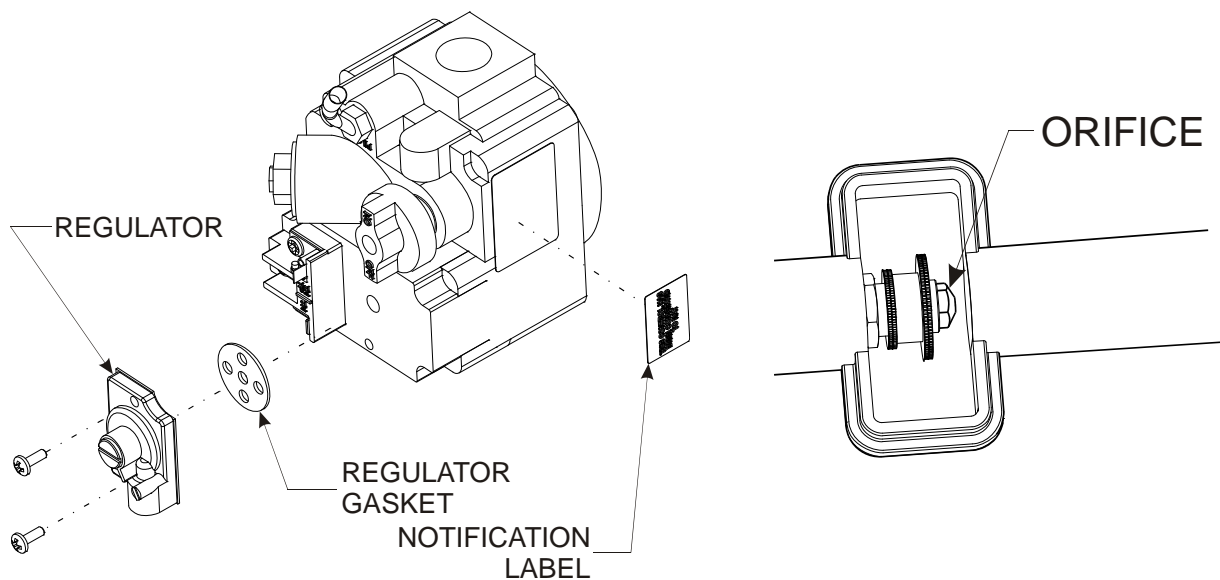

TROUBLESHOOTING

All technical problems should only be investigated by qualified gas fitters or service technicians. Improper adjustment, alteration or service can cause property damage, injury or death. For problems with your gas supply or oven operation contact your gas supplier or contact a Bakers Pride Authorized Service Agency.

PROBLEM	POSSIBLE	REMEDY
No Pilot	No Gas	Gas supply shut-off.
		Shut-off valve in "OFF" position.
		Kink in supply tube from valve. Inspect entire length
		Blocked supply line
		Faulty valve
	Dirty Orifice	Make sure pilot orifice is clean and not blocked. Care must be taken to clean but not enlarge orifice hole.
Pilot won't stay lit	Not Enough Gas	Gas flow too low. Check gas pressure
		Incorrect orifice. LP orifice in place of Natural.
		Blocked Orifice in pilot. Check and clean as required.
	Flame too small	Adjust pilot flame
	Dirty Contact	Jumper wire at thermostat posts on combination valve must be clean and tight.
		Thermopile must be clean and fastening nut tight to pilot bracket.
	Faulty Component	Faulty thermopile or thermocouple. See Thermopile Test Procedure.
	Faulty valve. Test for functioning Thermocouple or Thermopile. Change Valve	
Main Burner won't light	No Gas	No pilot
		Valve Shut-off
		Blocked supply line
		Faulty Valve. Test gas flow before changing.
		Faulty Thermostat. Test gas flow before changing.
	Not enough gas	Not enough supply. Test gas flow.
Yellow or lazy flame	Not enough air	Adjust air mixture at inspirator
	Not enough gas	Test gas pressure/flow
Flame lifting	Too much air	Adjust air mixture at inspirator
Flame flashes back	High gas pressure	Test gas pressure/flow
Flame POPS when turned off	Wrong orifice	Verify and change as needed
Flame too large	Over gassed	Test gas pressure/flow
	Wrong orifice	Verify and change as needed
Delayed ignition	Plugged burner	Clean
	Ventilation	Consult HVAC professional to verify air mixture
Oven takes too long to heat	Not enough gas	Test gas supply.

TROUBLESHOOTING

PROBLEM	POSSIBLE CAUSE	REMEDY
Oven temperature Too High/Too Low	Thermostat setting	Calibrate thermostat
	Ventilation	Incorrect air flow can affect oven performance. Have checked by a
Booster burner won't light	No gas	Gas valve for booster burner shut-off
		Blocked supply line
	No electric	No electric to oven
		Unplugged
		Switch shut-off
		No 24V to ignition module. Change transformer
	Ignitor failure	Ignitor doesn't light. Check voltage, change ignitor
		Soot in ignitor. Clean.
		Ignitor lights but doesn't pass enough current to module. Change ignitor
	Module failure	Module receives voltage but doesn't light ignitor. Change module.
		Module lights ignitor but doesn't sense its current. Change module.
		Module receives current from ignitor but fails to open gas valve. Change module.
Booster burner won't stay lit	No flame sense	Sense rod missing ground connection. Clean and tighten.
		Soot on sense rod. Clean.
		Sense rod fails. Change sense rod.

TROUBLE SHOOTING

TEMPERATURE CALIBRATION

Thermostats are calibrated at the manufacturer and field adjustments are seldom necessary. They should not be made unless actual cooking experience indicates the control is not maintaining set temperature. Breaking the seal on the calibration plate locking screws may void the manufacturer's warranty for the thermostat.

Use a digital thermometer.

Place a thermocouple along the capillary bulb in the oven cavity.

Close the door.

Light the main burner. Adjust temperature setting to 400°F.

Allow oven to heat until burner flame drops to by-pass.

Check temperature reading at thermometer. If not within 25° of set point adjust dial setting.

To adjust:

Pull knob straight off. Do NOT turn stem while removing knob.

Grasp calibration plate and hold in place while loosening two calibration lock screws. Use a #1 Phillips screwdriver.

The calibration plate has markings and the name "ROBERT SHAW" stamped in it. There are approximately 50° between each letter.

Turn calibration plate counter-clockwise to lower set point.

Turn calibration plate clockwise to increase set point.

Tighten locking screws and replace dial.

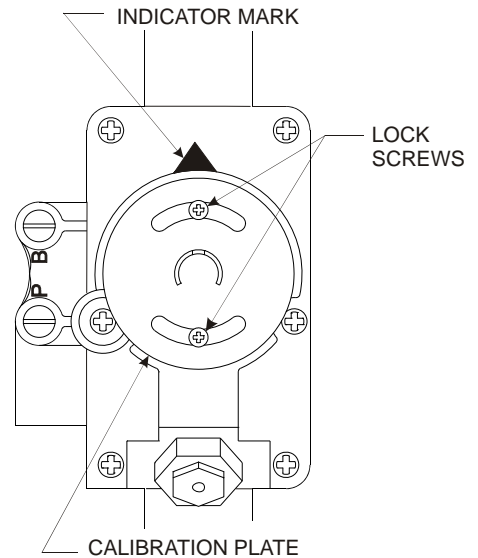

TEST THERMOPILE AND VALVE

Use these test procedures to trouble shoot the thermopile and combination gas valve. Prior to performing any tests clean and tighten all wire connections at the combination valve.

Clean the pilot orifice and insure the Thermopile is not coated with soot from a high pilot flame.

Use a digital volt meter with a scale capable of reading millivolts.

System Test - pilot lights, main burner does not.

Connect volt meter leads between terminal 2 and terminal 3. Turn gas cock dial to "ON". If meter reading is greater than 100 mV replace valve. If meter reading is less than 100 mV run additional tests.

Thermopile Output Test - pilot won't stay lit or main burner won't light.

Connect volt meter leads between terminal 1 and terminal 2. Remove jumper from terminal 3. Gas cock dial in "PILOT" position. If meter reading is less than 325 mV replace Thermopile.

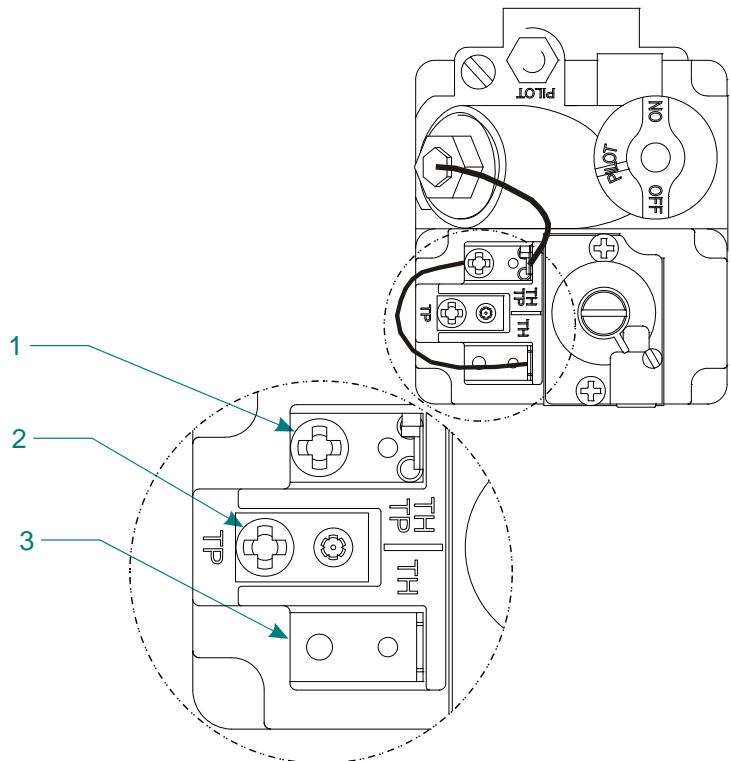

WARRANTY

WHAT IS COVERED: This warranty covers defects in material and workmanship under normal use, and applies only to the original purchaser providing that:

- ◆ The equipment has not been accidentally or intentionally damaged, altered or misused;
- ◆ The equipment is properly installed, adjusted, operated and maintained in accordance with National and local codes, and in accordance with the installation instruction provided with the product;
- ◆ The serial number rating plate affixed to the equipment has not been defaced or removed.

WHO IS COVERED: This warranty is extended to the original purchaser and applies only to equipment purchased for use in the U.S.A.

COVERAGE PERIOD: Full size gas and electric deck ovens: Two (2) year limited parts and labor. Cyclone Convection Ovens:

- ◆ BCO Models: One (1) Year limited parts and labor; (1) Year limited door warranty.
- ◆ GDCO Models: Two (2) Year limited parts and labor.
- ◆ CO11 Models: Two (2) Year limited parts and labor; (5) Year limited door warranty.
- ◆ All Other Products: One (1) Year limited parts and labor.
- ◆ Warranty period begins the date of dealer invoice to customer or ninety (90) days after shipment date from BAKERS PRIDE - whichever comes first.

WARRANTY COVERAGE: This warranty covers on-site labor, parts and reasonable travel time and travel expenses of the authorized service representative up to (100) miles, round trip, and (2) hours travel time. The purchaser, however, shall be responsible for all expenses related to travel, including time, mileage and shipping expenses on smaller counter models that may be carried into a Factory Authorized Service Center, including the following models: PX-14, PX-16, P18 and BK-18.

EXCEPTIONS: All removable parts in BAKERS PRIDE Char-broilers, including but not limited to: Burners, Grates, Radiants, Stones and Valves, are covered for a period of SIX MONTHS.
All Ceramic Baking Decks are covered for a period of THREE MONTHS. The installation of these replacement decks is the responsibility of the purchaser.
The extended Cyclone door warranty years 3 through 5 is a parts only warranty and does not include labor, travel, mileage or any other charges

EXCLUSIONS:

- ◆ Negligence or acts of God,
- ◆ Thermostat calibrations after (30) days from equipment installation date,
- ◆ Air and Gas adjustments,
- ◆ Light bulbs,
- ◆ Glass doors and door adjustments,
- ◆ Fuses,
- ◆ Char-broiler work decks and cutting boards,
- ◆ Tightening of conveyor chains,
- ◆ Adjustments to burner flames and cleaning of pilot burners,
- ◆ Tightening of screws or fasteners.
- ◆ Failures caused by erratic voltages or gas supplies,
- ◆ Unauthorized repair by anyone other than a BAKERS PRIDE Factory Authorized Service Center,
- ◆ Damage in shipment,
- ◆ Alteration, misuse or improper installation,
- ◆ Thermostats and safety valves with broken capillary tubes,
- ◆ Accessories - spatulas, forks, steak turners, grate lifters, oven brushes, scrapers, peels, etc.,
- ◆ Freight - other than normal UPS charges,
- ◆ Ordinary wear and tear

INSTALLATION: Leveling and installation of decks, as well as proper installation and check out of all new equipment — per appropriate installation and use materials — is the responsibility of the dealer or installer, not the manufacturer.

REPLACEMENT PARTS: BAKERS PRIDE genuine Factory OEM parts receive a (90) day materials warranty effective from the date of installation by a BAKERS PRIDE Factory Authorized Service Center.

This Warranty is in lieu of all other warranties, expressed or implied, and all other obligations or liabilities on the manufacturers part. BAKERS PRIDE shall in no event be liable for any special, indirect or consequential damages, or in any event for damages in excess of the purchase price of the unit. The repair or replacement of proven defective parts shall constitute a fulfillment of all obligations under the terms of this warranty.

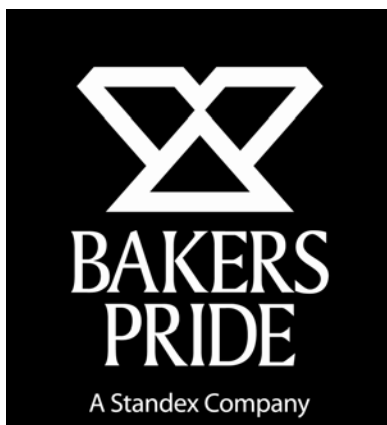

BAKERS PRIDE OVEN CO., INC.

30 Pine Street
New Rochelle, NY 10801

+1 (914) 576-0200 Phone
+1 (914) 576-0605 Fax

(800) 431-2745 US & Canada
www.bakerspride.com Web Address
info@bakerspride.com