



INSTALLATION AND OPERATION MAINTENANCE

CONVECTION OVEN

OWNER'S MANUAL

Models: BPCV-1, BPCV-1-1W, BPCV-1-2W, BPCV-2, BPCV-2-1W & BPCV-2-2W

All equipments manufactured by Bakers Pride Oven Co. Inc. for use with the type of gas specified on the rating plate and for installation will be in accordance with National Fuel Gas Code ANSI Z223.1 (latest edition)



FOR YOUR SAFETY: Do not store or use gasoline or other flammable vapors or liquids in the vicinity of this or any other appliance.



WARNING: Improper installation, adjustment, alteration, service or maintenance can cause property damage, injury or death. Read the installation, operating and maintenance instructions thoroughly before installing or servicing this equipment.



Instructions to be followed in the event the user smells gas must be posted in a prominent location in the kitchen area. This information shall be obtained from the local gas supplier.

PLEASE RETAIN THIS MANUAL FOR FUTURE REFERENCES.

P/N 340410 05/11

BAKERS PRIDE OVEN CO. INC.,

2205 South Standard Avenue
Santa Ana, CA 92707

(714) 424-9380 Phone
(714) 424-9385 Fax

www.bakerspride.com Web address

TABLE OF CONTENTS

Installation Instructions	2
Operating Instructions	3
Cleaning and Maintenance	8
Exploded View	10
Parts List	11
Warranty	13

IMPORTANT

Safe and satisfactory operation of your equipment depends to a great extent on its proper installation. Installation must conform with local codes or in the absence of local codes, the **National Fuel Gas Code, ANSI 2223.1** (latest edition.). In Canada, installation should conform to installation codes for gas burning appliances and equipment standard **CAN1-B149.1** (Natural. gas) or **CAN1-B149.2** (Propane gas).

Electrical wiring from the Electric Meter, main control box or service outlet to appliance must be electrically grounded in accordance with local codes or in the absence service of local codes with the **National Electrical Codes ANSI/NFPA 70** - current. In Canada, conform with Canadian **Electrical Code CSA-C22.1**

INSTALLATION INSTRUCTIONS

- Installation of the equipment should be performed by qualified, certified, licensed and /or authorized personnel who are familiar and experienced with local installation codes.
- Operation of the equipment should be performed by qualified or authorized personnel who have read this manual and are familiar with the functions of the equipment.
- Service of the equipment should be performed by qualified personnel who are knowledgeable with Bakers pride Cooking Equipments.

SHIPPING DAMAGE CLAIM PROCEDURE

The equipment is inspected and crated carefully by skilled personnel before leaving our factory. The transportation company assumes full responsibility for safe delivery upon acceptance of this equipment. If shipment arrives damaged:-

1. **Visible loss or damage:** Note on freight bill or express delivery and signed by person making delivery.
2. **File claim for damages immediately:** Regardless of extent of damages.
3. **Concealed loss or damage:** If damage is noticed after unpacking, notify Transportation Company immediately and file "Concealed Damage" claim with the transportation carrier. This should be done within fifteen (15) days from the date delivery and receipt of goods. Retain container for inspection.

GENERAL

1. A manual gas shut-off valve must be installed in the gas supply (service) line ahead of the appliance and gas pressure regulator for safety and ease in servicing.
2. The gas pressure regulator supplied must be installed on the appliance prior to connecting the equipment to the gas line. Failure to install a regulator could be potentially hazardous and will void the appliance warranty.
3. The appliance and its individual shut off valve must be disconnected from the gas supply piping system during any pressure testing of that system at test pressures in excess of ½ psi (3.45kpa).
4. The appliance must be isolated from gas supply piping system, by closing its individual manual shut off valve during any pressure testing of the gas supply piping system at test pressures equal to or less than ½ psi (3.45kpa).
5. To perform maintenance and repairs of the appliance, please contact the factory, the factory representative, or the nearest authorized local service company.

OPERATING INSTRUCTIONS

RATING PLATE

The rating plate is located in front of the range below the oven section. Information on this plate includes the model, serial number, BTU / hour input of the burners, operating gas pressure in inches WC, and whether the appliance is orificed for natural or propane gas. Pilot lighting instructions (ovens only) are also located in the same area.

BAKERS PRIDE COOKING APPLIANCES MUST BE CONNECTED ONLY TO THE TYPE OF GAS IDENTIFIED ON THE RATING PLATE

CLEARANCES

The appliance area must be kept free and clear of all combustibles. This unit is design-certified for the following installations only:

The clearances from **combustible** and **non combustible** construction are as follows:

	Combustible	Non combustible
Back	6"	0
Sides	6"	0

DO NOT MOUNT oven on a curb base. Use legs/casters provided. Adequate air space at the bottom and rear of the unit must be provided for proper venting of blower motor.

ASSEMBLY

DO NOT USE door to lift or move oven!!! All ovens must be installed on leg assembly or casters shipped with the unit

The leg/stand assembly parts or casters are shipped separately.

SINGLE OVEN

Assemble the leg/stand assembly as follows:

1. Remove legs from package.
2. Secure top frame parts to the legs with bolts provided (long angle - front & back. Short angle - sides).

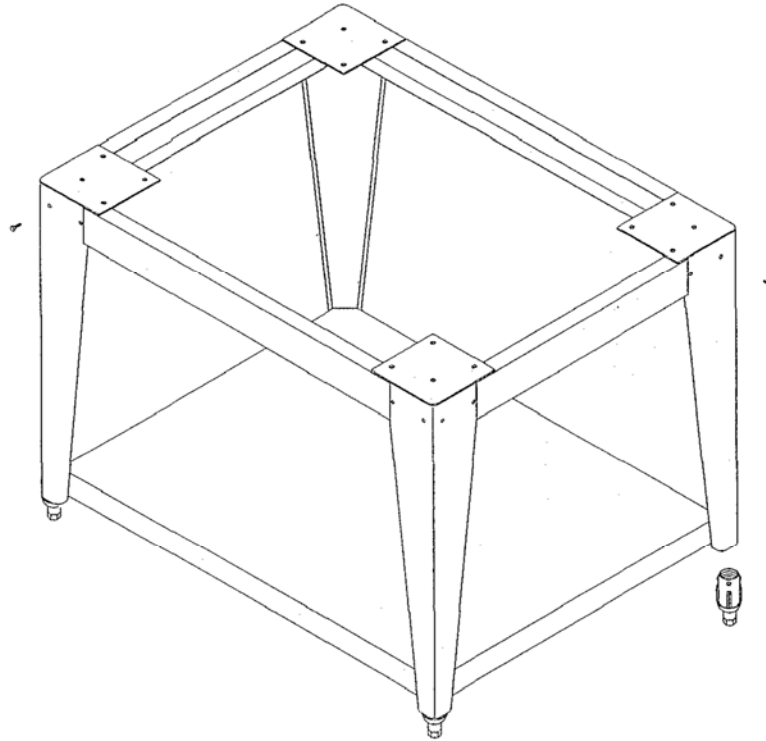

Figure 1

3. Place the oven on top of leg/stand assembly. Match holes on the frame with oven bottom base. Fasten with bolts provided

If provided with optional bottom shelf and rack support: (Ref. Figure 1)

- a. Screw the bottom shelf to the legs.
- b. Screw rack guide support angles to bottom shelf & top leg frame.

DOUBLE OVEN

6" leg assembly is provided.

1. Match holes on the legs with oven bottom base and screw with bolts provided.
2. Set top oven on top of bottom oven.
3. Bolts down at rear and front as shown in Figure 2. Remove top kick plate to access screwing the front bolts.
4. Assemble bottom flue extension as shown in Figure 2.

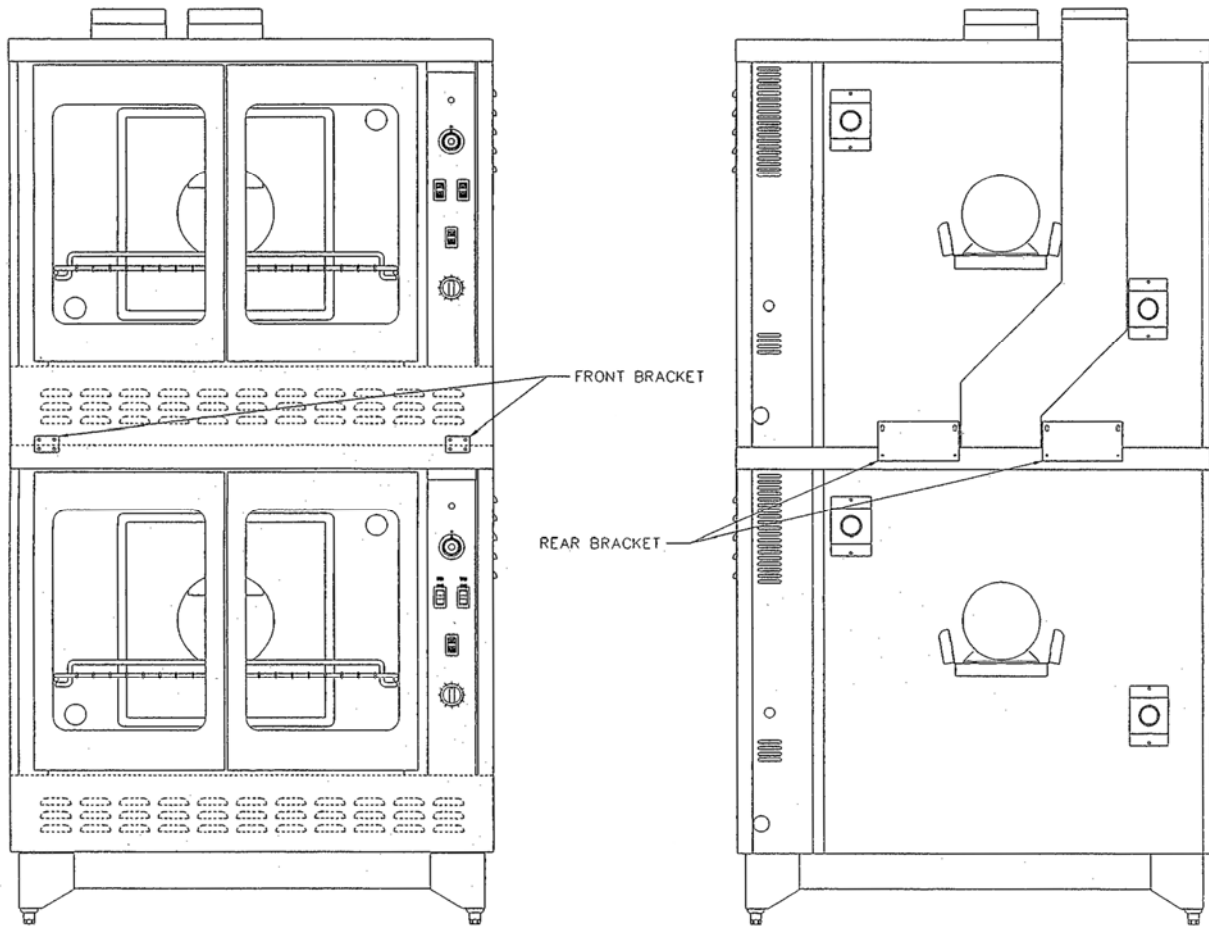

Figure 2

CASTER INSTALLATION

If casters are provided, match holes on the caster with holes on the oven bottom base and fasten with bolts provided.

NOTE: Front casters are locking type.

LEVELLING

A carpenter's spirit level should be used and placed on the oven's center baking rack and or across the range top and the unit leveled from front to back and side to side. If it is not level, cakes, casseroles and any other liquid or semi liquid batter will not bake evenly, burner combustion may be erratic, and the unit will not function efficiently.

If the floor is smooth and level, the appliance may be further leveled with adjustment in the foot of the leg. Units with castors require adjustment with shims. A unit will probably not return to the same position after being moved, requiring releveilling after each and every move.

AIR SUPPLY & VENTILATION

The area in front of, around and above the appliance must be kept clear to avoid any obstruction of the flow of combustion and ventilation air. Adequate clearance must be maintained around the appliance for servicing and proper operation.

Means must be provided for any commercial, heavy duty cooking appliance exhaust combustion waste products to the outside of the building. Usual practice is to place the appliance under an exhaust hood. Filters and drip troughs should be part of any industrial hood. But consult local codes before constructing and installing a hood.

Strong exhaust fans in this hood or in the overall air conditioning system can produce a slight vacuum in the room and / or cause air drafts, either of which can interfere with the pilot or burner performance and could be difficult to diagnose. Air movement should be checked during installation; if pilot or burner outage problems persist, make-up air openings or baffles may have to be provided in the room.

ELECTRICAL CONNECTION

Bakers Pride CONVECTION OVEN requires a 120 volt supply to operate the ignition system and circulating fan. The supply cord provided along with the appliance is equipped with a three prong (grounding) plug for protection against shock hazard. The electrical service in the building must be equipped with a properly grounded three prong receptacle, in accordance with local codes, or in the absence of local codes, with the national electrical code, **ANSI/NFPA 70-1987**, in Canada, conform with Canadian electrical codes, **CAS-C22.1**.

Do not cut or remove the grounding prong from this plug. Wiring diagram is located on the backside of the appliance. **Disconnect power supply before cleaning or servicing.**

NOTE: This appliance is not capable of being operated in the event of power failure. No attempt should be made to operate this appliance during power failure.

GAS CONNECTION

- Single Deck oven requires one gas connection.
- Double Deck oven requires two gas connections.

NOTE: The gas supply (service) line must be the same size or greater than the inlet line of appliance. Bakers Pride appliances use a $\frac{3}{4}$ " NPT inlet. Sealant on all pipe joints must be resistive to LP gas.

MANUAL SHUT-OFF VALVE

This installer-supplied valve must be installed in the gas service line ahead of the appliance and regulator in the gas stream and in a position accessible in the event of an emergency.

Failure to install the pressure regulator will void the equipment warranty!

The regulators supplied along with Bakers Pride appliances, will have $\frac{3}{4}$ " inlet/outlet openings and are adjusted at the factory for 5" WC (natural gas) or 10" WC (propane gas) depending on customer's ordering instructions.

Prior to connecting the regulator, check the incoming line pressure, as these regulators can only withstand a maximum pressure of $\frac{1}{2}$ " psi (14" WC). If the line pressure is beyond this limit, a step down regulator will be required.

The arrow shown on the bottom of the regulator body shows the gas flow direction, it should point downstream to the appliance. The red air vent cap on the top is part of the regulator and should not be removed.

Any adjustments to the regulator should be made by qualified service personnel only with the proper equipment.

CONNECTIONS

Please check installer supplied intake pipes visually and / or blow them out with compressed air to clear any dirt particles, threading chips or any other foreign matter before installing a service line. When gas pressure is applied, these particles could clog orifices.

All connections must be sealed with a joint compound suitable for LP gas, and all connections must be tested with a soapy water solution before lighting any pilots.

FLEXIBLE COUPLINGS, CONNECTOR AND CASTERS

If the unit is to be installed with flexible couplings and /or quick-disconnect fittings, the installer **must** use a **heavy-duty**, AGA design-certified commercial flexible connector of at least ¾" NPT (with suitable strain relief). The flexible connector must comply with the standard for **Connectors for Movable Gas Appliances, ANSI 221.69** and addendum **Z21.69a** (or latest edition) and a quick-disconnect device that complies with the standard for quick-disconnect devices for use with Gas Fuel should comply with **ANSI 221.41** and addendum **Z21.41a** (or latest edition). If disconnection of the restraint is necessary, make sure to reconnect restraint after the appliance has been returned to its originally installed position. Domestic gas or water connectors are not suitable,

Restraining device may be attached to the back frame/panel of unit.

If the unit is to be installed with casters, a flexible connector must be used and the same **ANSI** standards apply. Locking front casters are provided to limits the movement of the appliance without depending on the connector or associated piping. A suitable strain relief must be installed with the flexible connector.

All connections must be sealed with a joint compound suitable for LP gas and all connections must be tested with a soapy water solution before lighting pilots.

INITIAL PILOT LIGHTING



CAUTION: When lighting pilots and checking for leaks, do not stand with your face close to the combustion chamber.



All Bakers Pride appliances are adjusted and tested before leaving the factory, effectively matching them to sea level conditions. Adjustments and calibrations to assure proper operation may be necessary on installation to meet local conditions, low gas characteristics; correct possible problems caused by rough handling or vibration during shipment and are to be performed only by qualified service personnel. These adjustments are the responsibility of the customer and / or dealer and are not covered by our warranty.

Check all gas connections for leaks with a soapy water solution before lighting any pilots. **DO NOT USE AN OPEN FLAME TO CHECK FOR LEAKS!** Putting an open flame beside a new gas connection is extremely dangerous.

- a. Turn the thermostat dial to the "OFF" position. Place the power switch to the "OFF" position.
- b. Wait five minutes.
- c. Place power switch to the "ON" position. Turn the oven thermostat to the desired temperature.
- d. For a complete shutdown, place the thermostat and power switch in the "OFF" position.

TO CHECK FOR GAS LEAKS

1. Remove the kick plate and right side front panel
2. Check pilot tubing and burner tubing for leaks at the connectors with a soapy water solution.
3. Light the pilot as described above.
4. Turn the thermostat to any setting and the burner should light.
5. Check the burner orifice elbow connection downstream of the valve with a soapy water solution.
6. Check the burner visually for blue flame. There should be no yellow tips or soot. If yellow tipping occurs, call an authorized service person to adjust the burner air shutter.

TO CHECK FOR GAS LEAKS

On initial installation, turn the oven to 250 degrees and operate for about 1 hour, then reset then thermostat to its maximum and operate for another hour. This will drive off solvents remaining in the unit. At the end of this second hour, turn the thermostat OFF, open the door and allow the unit to cool. Oven should then be thoroughly washed using hot, soapy water before being used.

MAINTENANCE INSTRUCTIONS

CLEANING AND MAINTENANCE

Any equipment works better and lasts longer when maintained properly. Cooking equipment is no exception. Your Bakers Pride range and Oven must be kept clean on a daily basis.



CAUTION: Never use Ammonia in an oven that is warmer than room temperature and always have direct ventilation!



DAILY CLEANING

OVENS

1. Remove the baking racks. Wash in hot soapy water, and replace after the oven is fully cleaned.
2. Scrape off any food particles with a nylon griddle scraper. Be very careful about scratching the porcelain finish on the oven liner panels.
3. Wash all the above with hot soapy water, then reassemble.
4. Baked on spills may be loosened and stubborn stains removed with ordinary household ammonia and scrubbing with a nylon pad in a cold oven only.
5. Do not allow spray type oven cleaners to come into contact with the temperature probe in the oven.
6. After the cleaning the oven, rinse well with $\frac{1}{4}$ cup of vinegar to one quart of clean water solution to neutralize any caustic residue of the cleaning compound. Wipe dry.
7. To increase the life of the motor, follow these instructions:
 - a. Never run oven with motor off.
 - b. After you finish cooking and the oven is not to be used for more then $\frac{1}{2}$ hour. Place the switch to the "COOL DOWN position and open the door. When oven temperature is equal to room temperature turn unit off.

PERIODIC CLEANING

Check the ventilation system periodically to see that nothing has fallen down into the exhaust vents.

Lubricate the pivot pins of the oven door hinge. Use a multi-purpose lubricating oil sparingly so as to not drip oil needlessly.

Your appliance should be checked for safe and efficient operation at least once a year by qualified service personnel.

STAINLESS STEEL

All stainless steel body parts should be wiped regularly with hot soapy water during the day and with a liquid cleaner designed for this material at the end of each day.

DO NOT USE steel wool, abrasive cloth, or powders to clean stainless surfaces. If it is necessary to scrape stainless steel to remove encrusted materials, soak in hot water to loosen the material, and then use a wood or nylon scraper.

DO NOT USE a metal knife, spatula, or any other metal tool to scrape stainless steel. Scratches are almost impossible to remove.

Contact the factory, factory representative or a local service company to perform all Maintenance and Service repairs.
--

BPCV BAKERS PRIDE – CONVECTION OVEN

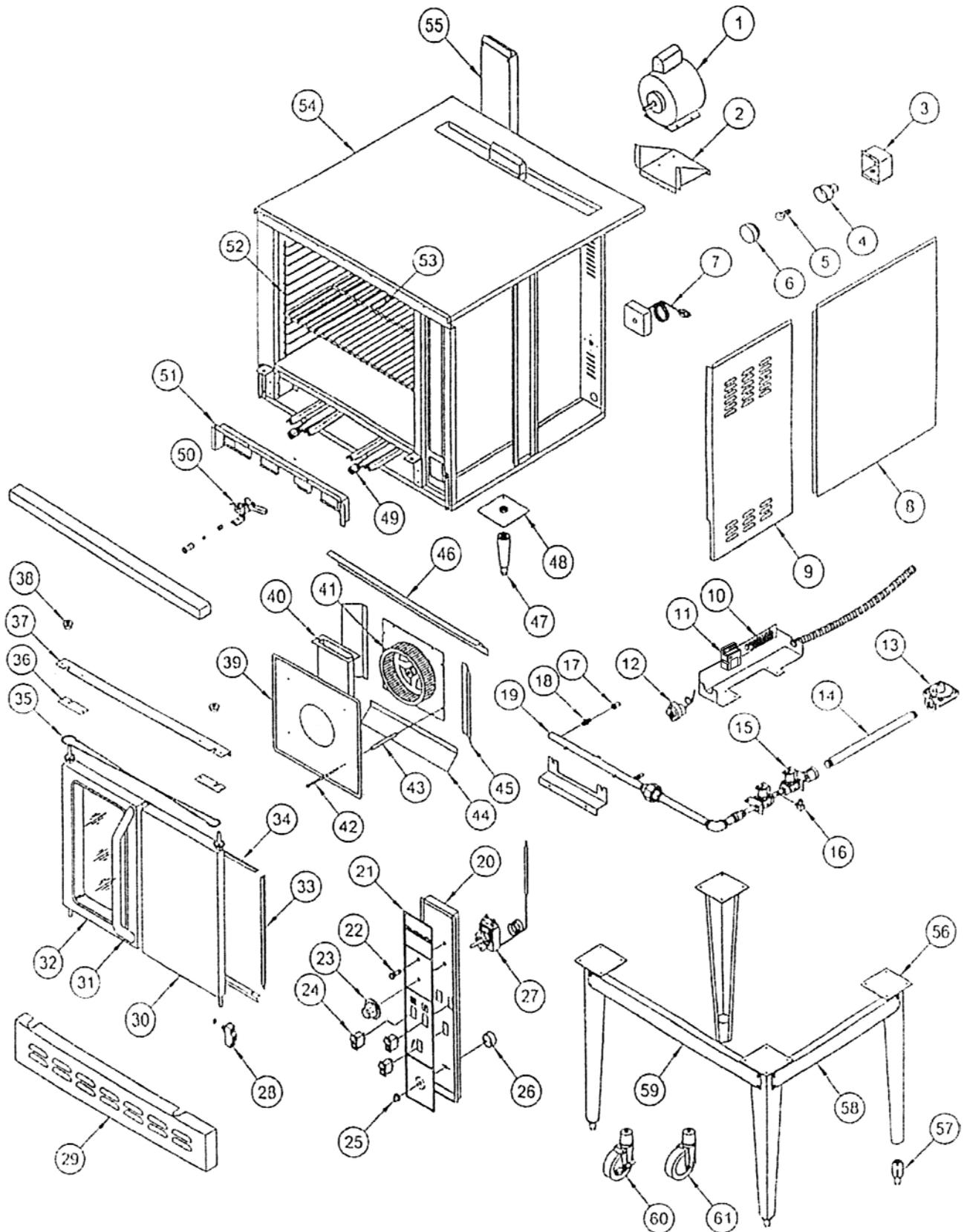

BPCV BAKERS PRIDE – CONVECTION OVEN

Item	Part #	Description	Item	Part #	Description
1	340115	MOTOR ½ HP 120V 50/60HZ	28	340289	DOOR SWITCH – PLUNGER STYLE
2	340136	MOTOR BRACKET	29	340162	KICK PLATE
3	340135	LIGHT BOX	30	390145 390148 340117	DOOR ASSY – R/H WITH GLASS DOOR ASSY – R/H WITH SOLID GLASS WINDOW ASSY ONLY
4	340283	LIGHT SOCKET PART OF ASSEMBLY	31	340116	HANDLE-OVEN DOOR
5	340283	LIGHT BULB PART OF ASSEMBLY	32	390144 390177	DOOR ASSY – L/H WITH GLASS DOOR ASSY-L/H SOLID
6	340283	LIGHT COVER PART OF ASSEMBLY	33	340161	DOOR SEAL-SIDES
7	340341	POWER CORD 8 FEET	34	340160	DOOR SEAL-TOP, BOTTOM
8	340156	RIGHT SIDE PANEL-REAR	35	340315 340128 340253 340130 S3224A 340316	CHAIN, HT HD PRE STRETCHED LINK ROD, ¼ x 3" W/EYE COUPLER LINK ROD, ¼ x 20" W/EYE COUPLER TURN BUCKLE MASTER LINK COUPLING ¼ - 20 EYE ROD
9	340155	RIGHT SIDE PANEL-FRONT	36	340157	DOOR CHAIN SPROCKET HOLDER
10	340281	TERMINAL BLOCK (8 WAY)	37	340218	CHANNEL SPROCKET SUPPORT
11	340134	IGNITION MODULE	38	340251	BUSHING, ½" DIA, BRONZE
12			39	340144	BLOWER BAFFLE
13	310354 310226	REGULATOR (NAT) REGULATOR (LP)	40	340363	SNORKLE TUBE ASSY
14	N5235Z	PIPE EXTENSION ¾ NPT x 19" (GAS INLET)	41	310912	BLOWER WHEEL
15	340267	SOLENOID, FJ GAS	42	300186	BOLT, ¼ - 20 x 5", HEX HEAD
16	340361	PILOT VALVE – ⅛ NPT x ¼ CC x 90	43	340327	SPACER TUBE ¾" O.D. x 4-¼" S/S
17	301034 301050	ORIFICE HOOD – #31 (45,000 BTU NAT) ORIFICE HOOD – #50 (45,000 BTU LP)	44	340222	DIVERTER-BOTTOM
18	311028	ADAPTER – ⅛ NPT Ex ¾ - 27 STRAIGHT	45	340223	DIVERTER-SIDES
19	340362	MANIFOLD PIPE	46	340221	DIVERTER-TOP
20	340617	CONTROL PANEL	47	340122	LEG 6" S/STEEL – WITH ADJUSTABLE FOOT (TSCV-2)
21	340273	DECAL (CONTROL PANEL)	48	340180	LEG PLATE ASSY (TSCV-2)
22	340285	INDICATOR LIGHT	49	340364	BURNER
23	340294	KNOB-THERMOSTAT	50 NAT	340131 300227	PILOT, 6S30-2 PILOT BELL ORIFICE – 3/16 CC #26 (NAT)
24	340284 340287 340288	SWITCH, FAN-2 SPEED SWITCH, LIGHT – MOMENTARY OVEN LIGHT SWITCH SWITCH, POWER – 3 POSITION, ON OFF COOL DOWN	50 LP	340131 300226	PILOT, 6S30-2 PILOT BELL ORIFICE – 3/16 CC #16 (LP)
25	340262	KNOB-TIMER	51	340170	FRONT BAFFLE-OVEN
26	340261	TIMER	52	340124 340123	RACKGUIDE –R/H RACKGUIDE –L/H
27	340132	THERMOSTAT	53	340125	RACK

**BPCV
BAKERS PRIDE – CONVECTION OVEN**

Item	Part #	Description	Item	Part #	Description
54	340151	TOP PANEL	64	390115	KIT,26.5" LEGS AND CASTERS
55	390106 390178	STACKING KIT WITH FEET STACKING KIT WITH CASTERS	65	390166	KIT,26.5" LEGS,CASTERS AND SHELF
56	340321	LEG ASSY (SINGLE UNIT)	66	390167	KIT,26.5" LEGS,CASTERS,SHELF AND RACK GUIDES
57	390168	FOOT	68	390169	KIT,26.5" LEGS AND ADJUSTABLE FEET
58	340178	BOTTOM LEG FRAME - SIDES	69	390170	KIT, 26.5" LEGS,ADJUSTABLE FEET AND SHELF
59	340177	BOTTOM LEG FRAME - FRONT & REAR	70	390171	KIT, 26.5" LEGS, ADJUSTABLE FEET, SHELF AND RACK GUIDES
60	340263	CASTER WITH BRAKE (FRONT)			
61	340264	CASTER WITH NO BRAKE (REAR)			
62	340360	WIRING DIAGRAM (NOT SHOWN)			
63	340360	WIRE HARDNESS (NOT SHOWN)			



BAKERS PRIDE LIMITED WARRANTY

2205 S. Standard Avenue, Santa Ana, CA 92707
Phone: (714) 424-9380 w Fax:(714) 424-9385

WHAT IS COVERED	<p>This warranty covers defects in material and workmanship under normal use, and applies only to the original purchaser providing that:</p> <ul style="list-style-type: none">• The equipment has not been accidentally or intentionally damaged, altered or misused;• The equipment is properly installed, adjusted, operated and maintained in accordance with National and local codes and in accordance with the installation instruction provided with the product;• The serial number rating plate affixed to the equipment has not been defaced or removed.
WHO IS COVERED	<p>This warranty is extended to the original purchaser and applies only to equipment purchased for use in the U.S.A.</p>
COVERAGE PERIOD	<p>Cyclone Convection Ovens: BCO Models: One (1) Year limited parts and labor; (1) Year limited door warranty. GDCO Models: Two (2) Year limited parts and labor; (2) Year limited door warranty. CO11 Models: Two (2) Year limited parts and labor; (5) Year limited door warranty. All Other Products: One (1) Year limited parts and labor. Warranty period begins the date of dealer invoice to customer or ninety (90) days after shipment date from BAKERS PRIDE - whichever comes first.</p>
WARRANTY COVERAGE	<p>This warranty covers on-site labor, parts and reasonable travel time and travel expenses of the authorized service representative up to (100) miles, round trip, and (2) hours travel time. The purchaser, however, shall be responsible for all expenses related to travel, including time, mileage and shipping expenses on smaller counter models that may be carried into a Factory Authorized Service Center, including the following models: PX-14, PX-16, P18, P22S, P24S, PD-4, PDC, WS Series and BK-18.</p>
EXCEPTIONS	<p>All removable parts in BAKERS PRIDE Char-broilers, including but not limited to: Burners, Grates, Radiants, Stones and Valves, are covered for a period of SIX MONTHS. All Ceramic Baking Decks are covered for a period of THREE MONTHS. The installation of these replacement decks is the responsibility of the purchaser. The extended Cyclone door warranty years 3 through 5 is a parts only warranty and does not include labor, travel, mileage or any other charges.</p>
EXCLUSIONS	<ul style="list-style-type: none">• Negligence or acts of God,• Thermostat calibrations after (30) days from equipment installation date,• Air and Gas adjustments,• Light bulbs,• Glass doors and door adjustments,• Fuses,• Char-broiler work decks and cutting boards,• Tightening of conveyor chains,• Adjustments to burner flames and cleaning of pilot burners,• Tightening of screws or fasteners.• Failures caused by erratic voltages or gas supplies,• Unauthorized repair by anyone other than a BAKERS PRIDE Factory Authorized Service Center,• Damage in shipment,• Alteration, misuse or improper installation,• Thermostats and safety valves with broken capillary tubes,• Accessories — spatulas, forks, steak turners, grate lifters, oven brushes, scrapers, peels, etc.,• Freight — other than normal UPS charges,• Ordinary wear and tear.
INSTALLATION	<p>Leveling and installation of decks as well as proper installation and check out of all new equipment —per appropriate installation and use materials — is the responsibility of the dealer or installer, not the manufacturer.</p>
REPLACEMENT PARTS	<p>BAKERS PRIDE genuine Factory OEM parts receive a (90) day materials warranty effective from the date of installation by a BAKERS PRIDE Factory Authorized Service Center.</p>

This Warranty is in lieu of all other warranties, expressed or implied, and all other obligations or liabilities on the manufacturer's part. BAKERS PRIDE shall in no event be liable for any special, indirect or consequential damages, or in any event for damages in excess of the purchase price of the unit. The repair or replacement of proven defective parts shall constitute a fulfillment of all obligations under the terms of this warranty.



BAKERS PRIDE OVEN CO. INC

2205 S. Standard Avenue
Santa Ana, CA 92707

(714) 424-9380 Phone
(714) 424-9385 Fax

www.bakerspride.com Web Address