



INSTALLATION AND OPERATION MAINTENANCE

BP SERIES – RANGE

OWNER'S MANUAL

Models:

**24BP4BS20, 36BP6BS30, 48BP8BS20
60BP10BS26, 60BP10BS30S20, 60BP6BG24S26
60BP6BG24S30S20, 60BP6BRG24S26, 60BP6BRG24S30S20
65BP10BS30, 72BP12BS30**

All equipments manufactured by Bakers Pride Oven Co. Inc. for use with the type of gas specified on the rating plate and for installation will be in accordance with National Fuel Gas Code ANSI Z223.1 (latest edition)



FOR YOUR SAFETY: Do not store or use gasoline or other flammable vapors or liquids in the vicinity of this or any other appliance.



WARNING: Improper installation, adjustment, alteration, service or maintenance can cause property damage, injury or death. Read the installation, operating and maintenance instructions thoroughly before installing or servicing this equipment.



Instructions to be followed in the event the user smells gas must be posted in a prominent location in the kitchen area. This information shall be obtained from the local gas supplier.

PLEASE RETAIN THIS MANUAL FOR FUTURE REFERENCES.

P/N 312644 03/11

BAKERS PRIDE OVEN CO. INC.,

2205 South Standard Avenue
Santa Ana, CA 92707

(714) 424-9380 Phone
(714) 424-9385 Fax

www.bakerspride.com Web address

TABLE OF CONTENTS

Installation Instructions	2
Operating Instructions.....	3
Maintenance Instructions	3
Cleaning and Maintenance	7
Exploded View – Griddles – BP	9
Parts List – Griddles – BP.....	10
Exploded View – Raised Griddles – BP	12
Parts List – Raised Griddles – BP.....	13
Warranty	14

INSTALLATION INSTRUCTIONS

- Installation of the equipment should be performed by qualified, certified, and authorized personnel who are familiar and experienced with local installation codes.
- Before Installation please read instructions completely and carefully.
- Do not remove permanently affixed labels, warnings or plates from the product.

SHIPPING DAMAGE CLAIM PROCEDURE

The equipment is inspected and crated carefully by skilled personnel before leaving our factory. The transportation company assumes full responsibility for safe delivery upon acceptance of this equipment. If shipment arrives damaged:-

1. **Visible loss or damage:** Note on freight bill or express delivery and signed by person making delivery.
2. **File claim for damages immediately:** Regardless of extent of damages.
3. **Concealed loss or damage:** If damage is noticed after unpacking, notify Transportation Company immediately and file “Concealed Damage” claim with the transportation carrier. This should be done within fifteen (15) days from the date delivery and receipt of goods. Retain container for inspection.

- Please observe all local and national codes and ordinances
- Installation must conform with local codes, or in the absence of local codes, the National Fuel Gas Code, ANSI Z223.1 (latest edition)
In Canada, installation should conform to installation codes for gas burning appliances and equipment standard CAN/CGA-B149.1 or the Propane installation code, CAN/CGA-B149.2, as applicable.
- Electrical wiring to the appliance must be electrically grounded in accordance with local codes or in the absence of local codes with the National Electrical Code ANSI/NFPA 70, or the Canadian Electrical Code, CSA C22.2, as applicable.
- A manual gas shut-off valve must be installed in the gas supply line ahead of the appliance and gas pressure regulator for safety and ease in servicing.
- The gas pressure regulator supplied must be installed on the appliance prior to connecting the equipment to the gas line. Failure to install a regulator could be potentially hazardous and will void the appliance warranty.
- The appliance and its individual shut off valve must be disconnected from the gas supply piping system during any pressure testing of that system at test pressures in excess of ½ psi (3.45kpa).
- The appliance must be Isolated from gas supply piping system, by closing its individual manual shut off valve during any pressure testing of the gas supply piping system at test pressures equal to or less than ½ psi (3.45kpa)

OPERATING INSTRUCTIONS

Operation of this equipment must be performed by qualified or authorized personnel who have read and are familiar with the functions of the equipment.

MAINTENANCE INSTRUCTIONS

RATING PLATE

The rating plate is located in front of the range below the oven section. Information on this plate includes the model, serial number, BTU / hour input of the burners, operating gas pressure in inches WC, and whether the appliance is orificed for natural or propane gas. Pilot lighting instructions (ovens only) are also located in the same area. The Salamander broiler, or Cheesemelter (if provided) are supplied with their own rating plates.

When communicating with factory about a unit or requesting for special parts or information, rating plate data is essential for proper identification.

BAKERS PRIDE COOKING APPLIANCES MUST BE CONNECTED ONLY TO THE TYPE OF GAS IDENTIFIED ON THE RATING PLATE

CLEARANCES

The appliance area must be kept free and clear of all combustibles.

The clearances from combustible and non combustible construction of ranges and range mounted Salamander broiler or Cheesemelter are as follows.

	Combustible	Non combustible
Back	4"	0
Sides	10"	0

If legs or casters are not used, the appliance must extend 2" beyond the front edge of a non combustible curb or platform.

HIGH SHELF ASSEMBLY

- Mount the High Shelf Assy to the range with # 10 sheet metal screws.
- If a Salamander broiler / Cheesemelter is to be mounted on Range, read installation instructions for Salamander / Cheesemelter before installing the High Shelf. Care must be taken to ensure gas supply piping and / or gas supply regulator is not exposed to exhaust gases, or elevated temperatures.

LEVELLING (Ranges equipped with Ovens)

A carpenter's spirit level should be used and placed on the oven's center baking rack and or across the range top and the unit leveled from front to back and side to side. If it is not level, cakes, casseroles and any other liquid or semi liquid batter will not bake evenly, burner combustion may be erratic, and the unit will not function efficiently.

If the floor is smooth and level, the appliance may be further leveled with adjustment in the foot of the leg. Units with castors require adjustment with shims. A unit will probably not return to the same position after being moved, requiring releveilling after each and every move. .

AIR SUPPLY & VENTILATION

The area in front of, around and above the appliance must be kept clear to avoid any obstruction of the flow of combustion and ventilation air. Adequate clearance must be maintained around the appliance for easy servicing.

Provision should be made for any commercial, heavy duty cooking appliance exhaust combustion waste products to the outside of the building. Usual practice is to place the appliance under an exhaust hood, which should be constructed in accordance to the local codes.

Strong exhaust fans in this hood or in the overall air conditioning system can produce a slight vacuum in the room and / or cause air drafts, either of which can interfere with the pilot or burner performance and could be difficult to diagnose. Air movement should be checked during installation. Air openings or baffles may have to be provided in the room, if pilot or burner outage problem persists.

GAS CONNECTION

The gas supply (service) line must be the same size or greater than the inlet line of the appliance. Bakers Pride ranges and ovens use a ¾" NPT inlet. Sealant on all pipe joints must be resistive to LP gas.

MANUAL SHUT OFF VALVE

This installer supplied valve must be in the gas service line ahead of the appliance regulator in the gas stream and in a position accessible in the event of an emergency.

PRESSURE REGULATOR

Commercial cooking equipment must have a pressure regulator on the incoming service line for safe and efficient operation, since service pressures may fluctuate on local demand. A pressure regulator is packed inside every BAKERS Pride range.

Failure to install the pressure regulator will void the appliance warranty.

The regulators supplied along with Bakers Pride appliances, will have ¾" inlet/outlet openings and are adjusted at the factory for 5" WC (natural gas) or 10" WC (propane gas) depending on customer's ordering instructions.

Prior to connecting the regulator, check the incoming line pressure, as these regulators can only withstand a maximum pressure of ½" psi (14" WC). If the line pressure is beyond this limit, a step down regulator will be required.

The arrow shown on the bottom of the regulator body shows the gas flow direction, it should point downstream to the appliance. The red air vent cap on the top is part of the regulator and should not be removed.

Any adjustments to the regulator should be made by qualified service personnel only with the proper equipment.

CONNECTIONS

Please check installer supplied intake pipes visually and / or blow them with compressed air to clear any dirt particles, threading chips or any other foreign matter before installing a service line. When gas pressure is applied, these particles could clog orifices.

All connections must be sealed with a joint compound suitable for LP gas, and all connections must be tested with a soapy water solution before lighting any pilots.

FLEXIBLE COUPLINGS, CONNECTOR AND CASTERS

For an appliance equipped with casters, the installation shall be made with a connector that complies with the Standard for Connectors for Movable Gas Appliances, ANSI Z21.69 or Connectors for Moveable Gas Appliances, CAN/CGA-6.16, and a quick disconnect device that complies with the Standard for Quick Disconnect Devices for Use With Gas Fuel, ANSI Z21.41, or Quick Disconnect Devices for Use With Gas Fuel, CANI-6.9.

If disconnection of the restraint is necessary, make sure to reconnect restraint after the appliance has been returned to its originally installed position. Domestic gas or water connectors are not suitable.

Restraining device may be attached to the back frame / panel of the unit.

If the appliance is to be installed with casters, a flexible connector must be used and the same ANSI standards apply. Locking front casters are provided to limit the movement of the appliance without depending on the connector or associated piping. A suitable strain relief must be installed with a flexible connector.

All connections must be sealed with a joint compound suitable for LP gas and all connections must be tested with soap water solution before lighting pilots.

INITIAL PILOT LIGHTING



CAUTION: When lighting pilots and checking for leaks, do not stand with your face close to the combustion chamber.



All Bakers Pride appliances are adjusted and tested before leaving the factory, effectively matching them to sea level conditions. Adjustments and calibrations to assure proper operation may be necessary on installation to meet local conditions, low gas characteristics; correct possible problems caused by rough handling or vibration during shipment and are to be performed only by qualified service personnel. These adjustments are the responsibility of the customer and / or dealer and are not covered by our warranty.

Check all gas connections for leaks with a soapy water solution before lighting any pilots.

DO NOT USE ANY FLAME TO CHECK FOR LEAKS

Before lighting any pilots, make sure that burner valves and thermostats are turned "OFF".

TOP BURNERS / RAISED GRIDDLE / BROILER

All top section burners are equipped with constant burning pilots. These are to be manually lighted immediately after the gas is turned on and the system is checked for leaks. Burner pilots are provided for each burner and can be rechecked for proper adjustment. All adjustments can be made with a screw driver to the brass pilot valve accessible through the valve cover.

GRIDDLE

The pilot should be lighted immediately after the gas is turned on and the system is checked for leaks. The pilot can be reached with a long match through the valve cover, or by lifting the plate upward and accessing through the top. Adjustment of the pilot flame can be made with a screwdriver to the pilot valve, accessible through the valve cover.

STANDARD OVEN

Pilot gas is tapped from the main burner manifold pipe, routed through tubing to a safety valve, and then to a pilot burner. Gas flow is controlled by the safety valve.

Oven pilot lighting or relighting is to be completed as follows:

- Turn the thermostat knob to "OFF" position and wait for 5 minutes.
- Open the oven's lower kick plate by lifting up and out. This exposes the pilot valve and the igniter button.
- Make sure accumulated gas if any has dispersed. Since propane gas is heavier than air, check near the floor area for the odor of propane gas before attempting to light any pilot burner.
- Depress the red button on the safety valve and hold it in, throughout the lighting procedure.
- Press the red button of the pilot ignitor and you should hear a snap and see a spark at the pilot burner. If a spark or spark ignitor is not present apply a lit match to the pilot burner head.
- Continue to depress the safety valve button until the pilot remains lit when released.
- If pilot is extinguished, repeat steps 4 through 6 above.
- Turn the oven thermostat knob "ON" and set to desired temperature setting, watch to make sure the oven burner ignites from the pilot and that there are no yellow flames from the burner.
- Turn the oven thermostat to the "OFF" and replace the lower kick plate.

NOTE: It may be necessary to relight the pilot several times until the lines are purged of any trapped air and a constant gas flow is attained.

For complete shutdown, turn all burner valves, pilot valves and thermostats to the "OFF" position. Turn shut off valve.

BEFORE 1st USE

Griddles

- Clean the griddle surface thoroughly with hot, soapy water to remove protective oil coating applied at the factory.
- Rinse with a mixture of ¼ cup vinegar to one quart water.
- Spread unsalted solid shortening or liquid frying compound evenly over the entire griddle surface.
- Turn all griddle burners to medium and wait until the shortening begins to smoke, then turn the burners "OFF".
- Rub the now melted shortening into the griddle surface with burlap, moving in the direction of the surface's polish marks and covering the entire surface.
- Allow the griddle to cool.
- When the griddle is cool after the second seasoning, wipe it with a thin film of shortening or cooking oil.

Ovens

On initial installation turn the oven to 250 degrees and operate for hour, then reset the thermostat to its maximum and operate for another hour. This will drive off any solvents remaining in the unit. At the end of this second hour, turn the thermostat "OFF", open the door and allow the unit to cool. Oven should then be thoroughly washed using hot soapy water before being used.

CLEANING AND MAINTENANCE

Any equipment works better and lasts longer when maintained properly. Cooking equipment is no exception. Your Bakers Pride range and Oven must be kept clean on a daily basis.



CAUTION: Never use Ammonia in an oven that is warmer than room temperature and always have direct ventilation!



DAILY MAINTENANCE

OPEN BURNERS

- Remove all top grates.
- Lift off the burner heads and venturies by raising the head slightly, sliding to the rear of the range and lifting upwards.
- Wash all of the above in hot, soapy water.
- Re-install burner parts in the reverse order.

GRIDDLES

- Scrape with a nylon griddle scraper to remove cooked on spills. When absolutely necessary use a fine grained stone to scrape.
- Wipe away any griddle stone dust and food particles with burlap.
- Wash with hot, soapy water, then rinse with vinegar and water.
- Rinse again with clear water.
- Re-oil with shortening or liquid frying compound.
- DO NOT FLOOD A HOT GRIDDLE WITH COLD WATER. This could cause warping and griddle plate to crack.

OVENS

- Remove the baking racks. Wash in hot soapy water, and replace after the oven is fully cleaned.
- Remove the oven bottom by lifting it out from the front, then sliding forward, out of the oven.
- Scrape off any food particles with a nylon griddle scraper. Be very careful about scratching the porcelain finish on the oven liner panels.
- Wash all the above with hot soapy water, then reassemble.
- Baked on spills may be loosened and stubborn stains removed with ordinary household ammonia and scrubbing with a nylon pad in a cold oven only.
- Do not allow spray type oven cleaners to come into contact with the temperature probe in the oven.
- After the cleaning the oven, rinse well with $\frac{1}{4}$ cup of vinegar to one quart of clean water solution to neutralize any caustic residue of the cleaning compound. Wipe dry.

PERIODIC CLEANING

Check the ventilation system periodically to see that nothing has fallen down into the stub back, high riser or high shelf exhaust vents. Lubricate the pivot pins of the oven door hinge where the right and left

arms connect to the door. Use lubricating oil. Ensure your Bakers Pride range be checked by a qualified technician once a year for efficient operation of the appliance.

STAINLESS STEEL

All stainless steel body parts should be wiped regularly with hot soapy water during the day and with a liquid cleaner designed for this material at the end of each day. **DO NOT USE** steel wool, abrasive cloth, or powders to clean stainless surfaces. If it is necessary to scrape stainless steel to remove encrusted materials, soak in hot water to loosen the material, then use a wood or nylon scraper. **DO NOT USE** a metal knife, spatula, or any other metal tool to scrape stainless steel. Scratches are almost impossible to remove.

Contact the factory, factory representative or a local service company to perform all Maintenance and Service Repairs.
--

BAKERS PRIDE – RANGE SERIES

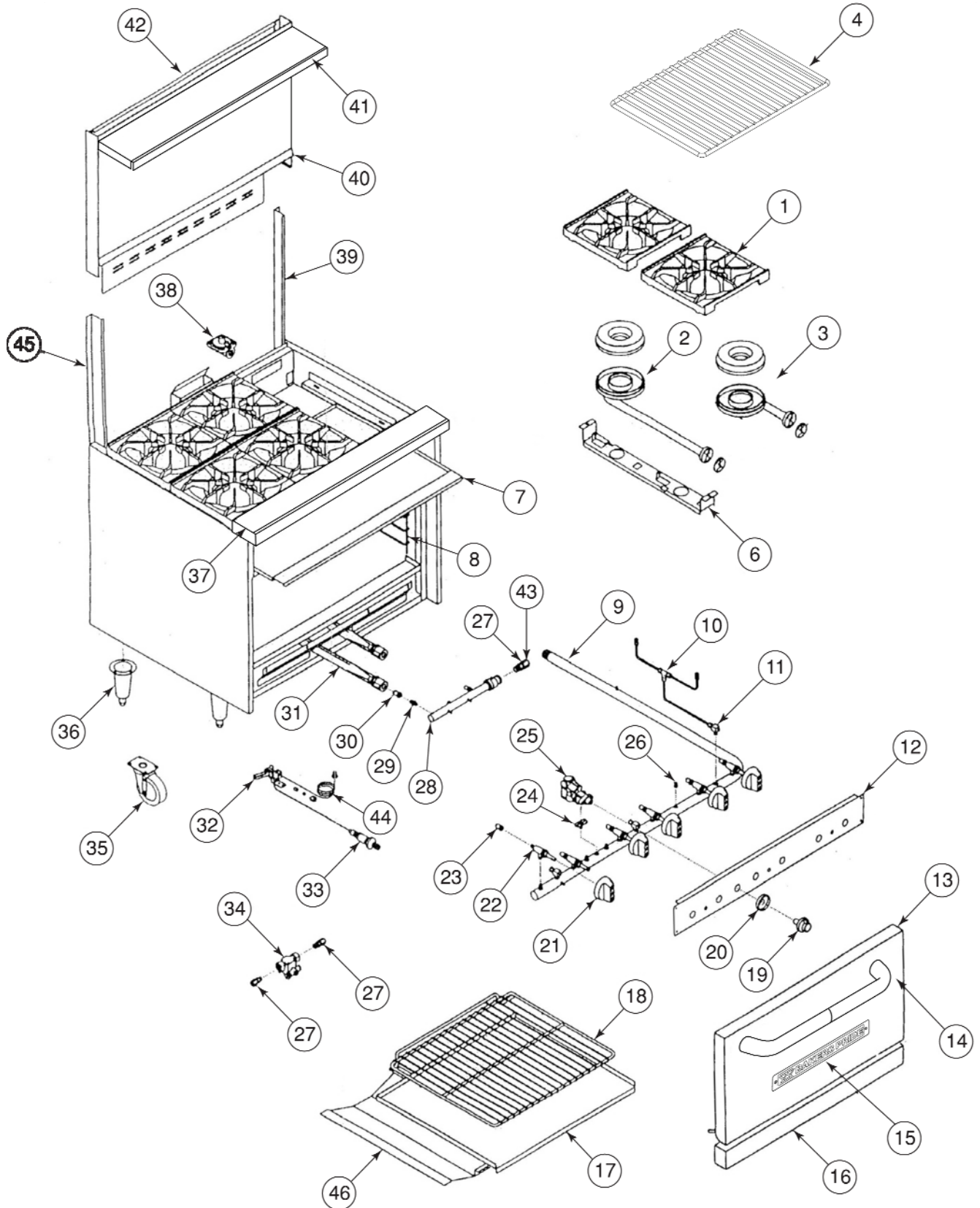

**BAKERS PRIDE – RANGE SERIES
WITH GRIDDLES AND RAISED GRIDDLES**

Item	Part #	Description	Item	Part #	Description
1	311016	TOP GRATE 12" X 12"	18	314010	RACK 24" RAISED GRIDDLE
2	312619	BURNER LONG VENTURI BAKERS PRIDE	19	310299	KNOB OVEN RANGE 500
3	312618	BURNER SHORT VENTURI BAKERS PR	20	310295	BEZEL THERMOSTAT
4	311031 311032 310510	RACK 20" OVEN RACK 26 1/2" OVEN RACK 30" OVEN	21	310154	KNOB METAL BLUE STRIP SET SCREW
6	310266	BURNER HANGER	22	R3032A	VALVE GAS
7	312634 312635	CRUMB TRY 24" RANGE S/S CRUMB TRY 36" RANGE S/S	23	301034 301050 301046 301055	ORIFICE, RANGE NAT 40,000 ORIFICE, RANGE LP 40,000 ORIFICE, RAISED GRIDDLE NAT 20,000 ORIFICE, RAISED GRIDDLE LP 20,000
8	310394 311035	RACK SUPPORT SIDE 20" & 30" OVENS RACK SUPPORT SIDE 26 1/2" OVEN	24	2000101	FLANGE THERMOSTAT
9	310389 311037 310310 310514 315710 310713 311810	MANIFOLD 24" RANGE MANIFOLD 36" RANGE MANIFOLD 48" RANGE MANIFOLD 60" RANGE MANIFOLD 60" RANGE / 24" GRIDDLE RT MANIFOLD 24" RANGE GRIDDLE MANIFOLD 72" RANGE	25	310326	THERMOSTAT, OVEN 500
10	300177	TEE 3/16" COMPRESSION	26	2092517	PLUG 1/8" NPT
11	311027	VALVE PILOT	27	370142	FITTING STRAIGHT – 1/4" NPT X 3/8" CC
12	314818 314117 316011 312643 317010 316413 316414 310490	COVER, VALVE 24" RANGE BAKERS PRIDE COVER, VALVE 36" RANGE BAKERS PRIDE COVER, VALVE 48" RANGE BAKERS PRIDE COVER, VALVE 60" RANGE BAKERS PRIDE COVER, VALVE 60" 24" GRIDDLE RIGHT BP COVER, VALVE 36" ZONES BAKERS PRIDE COVER, VALVE 24" RAISED GRIDDLE BP COVER, VALVE 72" RANGE BAKERS PRIDE	28	311038	MANIFOLD OVEN
13	390134 390135 390136	DOOR ASSEMBLY 20" OVEN BAKERS DOOR ASSEMBLY 26 1/2" OVEN BAKERS DOOR ASSEMBLY 30" OVEN BAKERS	29	311028	ADAPTER 1/8" MALENPT X 3/8"-27
14	312615 312616 312617	HANDLE 20" OVEN DOOR BP HANDLE 26 1/2" OVEN DOOR BAKERS HANDLE 30" OVEN DOOR BAKERS	30	301050 301056 301046 301055	ORIFICE HOOD #50 NAT 15,000 BTU OVEN ORIFICE HOOD #56 LP 15,000 BTU OVEN ORIFICE HOOD #46 NAT 20,000 BTU OVEN ORIFICE HOOD #55 NAT 20,000 BTU OVEN
15	U1066A	NAME PLATE BAKERS PRIDE	31	311026	BURNER STRAIGHT
16	310114 310425 310230	KICK PLATE 20" OVEN KICK PLATE 26 1/2" OVEN KICK PLATE 30" OVEN	32	310126	PILOT NAT RANGE OVEN
17	314810 310363 314111	BOTTOM 20" OVEN LARGE RIBS BOTTOM 26 1/2" OVEN LARGE RIBS BOTTOM 30" OVEN LARGE RIBS	33	310123	PIEZO MANUAL SPART IGNITOR

Item	Part #	Description	Item	Part #	Description
34	311011	PILOT SAFETY VALVE			
35	390210 390211	CASTER 5" PLATE CASTER 5" PLATE WITH BRAKE			
36	311039	LEG 6" STAINLESS			
37	314815 312613 316012 312623 316415 316210	LANDING LEDGE 24" BAKERS PRIDE LANDING LEDGE 36" BAKERS PRIDE LANDING LEDGE 48" BAKERS PRIDE LANDING LEDGE 60" BAKERS PRIDE LANDING LEDGE 24"RAISED GRIDDLE BP LANDING LEDGE 72" BAKERS PRIDE			
38	310354 310226 311029 311044	REGULATOR NAT 24"-36" RANGES REGULATOR LP 24"-36" RANGES REGULATOR NAT 48"-72" RANGES REGULATOR LP 48"-72" RANGES			
39	310345	CHANNEL SUPPORT RIGHT			
40	310124 310235 310366 311715 315716 311813	FRONT SHEET 24" HI-SHELF FRONT SHEET 36" HI-SHELF FRONT SHEET 48" HI-SHELF FRONT SHEET 60" HI-SHELF FRONT SHEET 60" HI-SHELF w/ RAISED GRIDDLE FRONT SHEET 72" HI-SHELF			
41	314816 314114 316013 312647 316211	SHELF TOP 24" RANGE BAKERS PRIDE SHELF TOP 36" RANGE BAKERS PRIDE SHELF TOP 48" RANGE BAKERS PRIDE SHELF TOP 60" RANGE BAKERS PRIDE SHELF TOP 72" RANGE BAKERS PRIDE			
42	310125 310236 310367 311715 318313 311814	BACK SHEET 24" HI-SHELF BACK SHEET 36" HI-SHELF BACK SHEET 48" HI-SHELF BACK SHEET 60" HI-SHELF BACK SHEET 60" HI-SHELF WITH RAISED GRIDDLE BACK SHEET 72" HI-SHELF			
43	310330	ELBOW 3/8 CC X 1/4 MNPT			
44	310210	THERMOCOUPLE 18"			
45	310237	CHANNEL SUPPORT LEFT			
46	310251	FLAME SPREADER			

RAISED GRIDDLE & FLAT GRIDDLE BAKERS PRIDE – RANGE SERIES

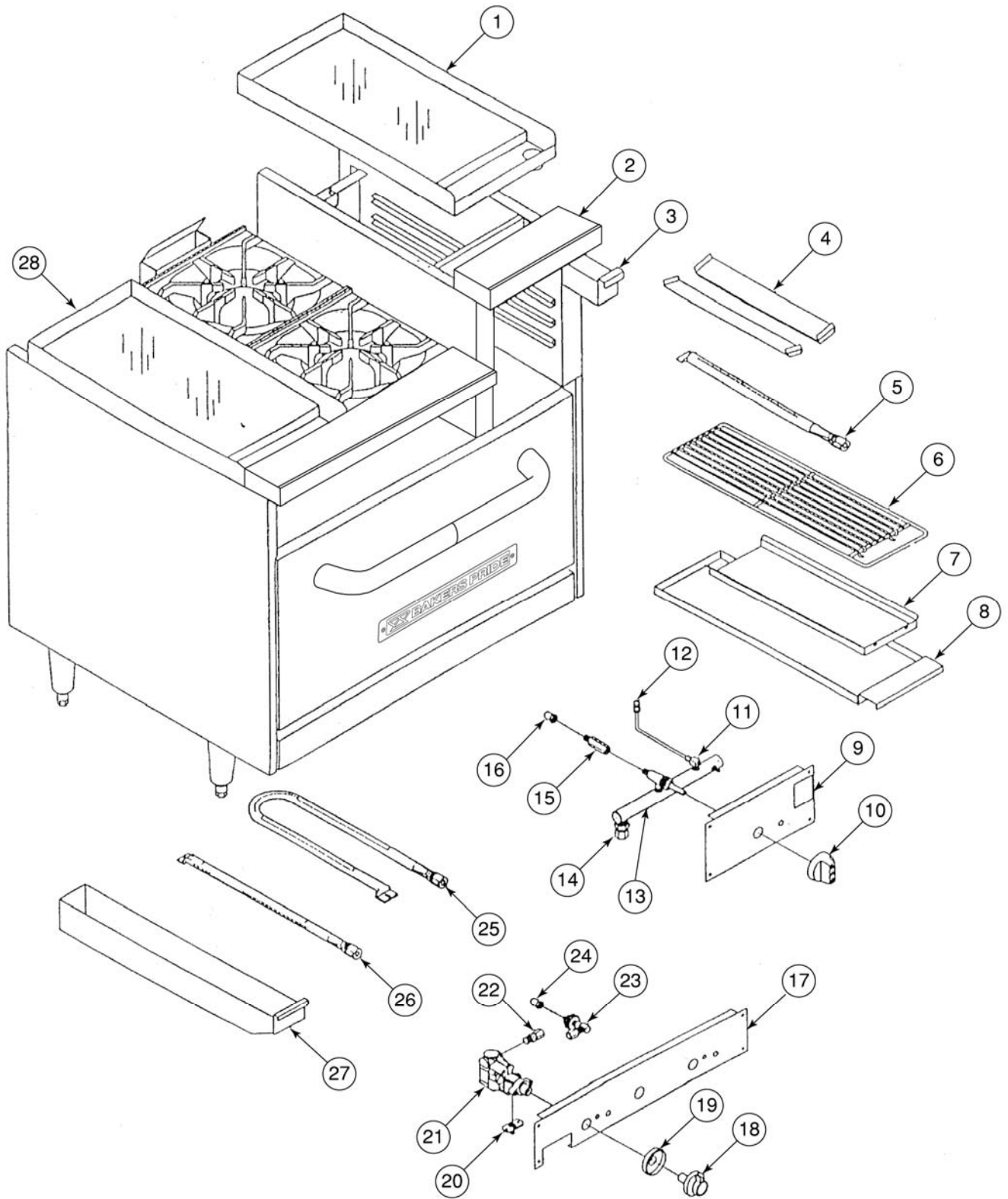

RAISED GRIDDLE & FLAT GRIDDLE BAKERS PRIDE – RANGE SERIES

Item	Part #	Description	Item	Part #	Description
1	310476 316410 312307	12" RAISED GRIDDLE PLATE 1" 24" RAISED GRIDDLE PLATE 1" 36" RAISED GRIDDLE PLATE 1"	17	-	VALVE COVER CONTACT FACTORY
2	310477 316415 310478	12" LANDING LEDGE RAISED GRIDDLE BP 24" LANDING LEDGE RAISED GRIDDLE BP 36" LANDING LEDGE RAISED GRIDDLE BP	18	310299	KNOB OVEN RANGE 500
3	318321	GREASE CAN RAISED GRIDDLE	19	310295	BEZEL
4	315728	RADIANT BURNER INSIDE	20	2000101	FLANGE THEROSTAT
5	311026	BURNER STRAIGHT	21	310326	THERMOSTAT 500F
6	314009 314010 314011	RACK 12" RAISED GRIDDLE RACK 24" RAISED GRIDDLE RACK 36" RAISED GRIDDLE	22	371043	FITTING STRAIGHT
7	310479 318328 310480	DRIP PAN 12" RAISED GRIDDLE DRIP PAN 24" RAISED GRIDDLE DRIP PAN 36" RAISED GRIDDLE	23	2092614	ELBOW 3/8 CC X 3/8 -27
8	310481 316411 310482	CRUMB TRAY 12" RAISED GRIDDLE S/S CRUMB TRAY 24" RAISED GRIDDLE S/S CRUMB TRAY 36" RAISED GRIDDLE S/S	24	301046 301055 301050 301057	ORIIFICE HOOD #46 NAT "U" BURNER ORIIFICE HOOD #455 LP "U" BURNER ORIIFICE HOOD #50 NAT STRAIGHT BURNER ORIIFICE HOOD #57 LP STRAIGHT BURNER
9	310483 316414 310484	VALVE COVER 12" RAISED GRIDDLE BP VALVE COVER 24" RAISED GRIDDLE BP VALVE COVER 36" RAISED GRIDDLE BP	25	360168	BURNER U
10	310154	KNOB METAL BLUE STRIP	26	311026	STRAIGHT BURNER
11	311027	VALVE PILOT	27	310710	GREASE CAN FLAT GRIDDLE
12	311036	PILOT TIP	28	310491 316310 312306	12" GRIDDLE PLATE WELDMENT 1" 24" GRIDDLE PLATE WELDMENT 1" 36" GRIDDLE PLATE WELDMENT 1"
13	310485 310713 310486	MANIFOLD 12" RAISED GRIDDLE MANIFOLD 24" RAISED GRIDDLE MANIFOLD 36" RAISED GRIDDLE			
14	370143	STRAIGHT FITTING 3/8 NPT X 3/8 CC			
15	300178	EXTENSION ORIFICE			
16	301046 301055	ORIFICIE HOOD #46 NAT 20,000 BTU ORIFICIE HOOD #55 LP 20,000 BTU			

Flat griddle is standard on right, shown on left is exploded view to show both raised and flat griddle parts.



BAKERS PRIDE LIMITED WARRANTY

2205 S. Standard Avenue, Santa Ana, CA 92707

Phone: (714) 424-9380 w Fax:(714) 424-9385

WHAT IS COVERED	<p>This warranty covers defects in material and workmanship under normal use, and applies only to the original purchaser providing that:</p> <ul style="list-style-type: none">• The equipment has not been accidentally or intentionally damaged, altered or misused;• The equipment is properly installed, adjusted, operated and maintained in accordance with National and local codes and in accordance with the installation instruction provided with the product;• The serial number rating plate affixed to the equipment has not been defaced or removed.
WHO IS COVERED	<p>This warranty is extended to the original purchaser and applies only to equipment purchased for use in the U.S.A.</p>
COVERAGE PERIOD	<p>Cyclone Convection Ovens: BCO Models: One (1) Year limited parts and labor; (1) Year limited door warranty. GDCO Models: Two (2) Year limited parts and labor; (2) Year limited door warranty. CO11 Models: Two (2) Year limited parts and labor; (5) Year limited door warranty. All Other Products: One (1) Year limited parts and labor. Warranty period begins the date of dealer invoice to customer or ninety (90) days after shipment date from BAKERS PRIDE - whichever comes first.</p>
WARRANTY COVERAGE	<p>This warranty covers on-site labor, parts and reasonable travel time and travel expenses of the authorized service representative up to (100) miles, round trip, and (2) hours travel time. The purchaser, however, shall be responsible for all expenses related to travel, including time, mileage and shipping expenses on smaller counter models that may be carried into a Factory Authorized Service Center, including the following models: PX-14, PX-16, P18, P22S, P24S, PD-4, PDC, WS Series and BK-18.</p>
EXCEPTIONS	<p>All removable parts in BAKERS PRIDE Char-broilers, including but not limited to: Burners, Grates, Radiants, Stones and Valves, are covered for a period of SIX MONTHS. All Ceramic Baking Decks are covered for a period of THREE MONTHS. The installation of these replacement decks is the responsibility of the purchaser. The extended Cyclone door warranty years 3 through 5 is a parts only warranty and does not include labor, travel, milage or any other charges.</p>
EXCLUSIONS	<ul style="list-style-type: none">• Negligence or acts of God,• Thermostat calibrations after (30) days from equipment installation date,• Air and Gas adjustments,• Light bulbs,• Glass doors and door adjustments,• Fuses,• Char-broiler work decks and cutting boards,• Tightening of conveyor chains,• Adjustments to burner flames and cleaning of pilot burners,• Tightening of screws or fasteners.• Failures caused by erratic voltages or gas supplies,• Unauthorized repair by anyone other than a BAKERS PRIDE Factory Authorized Service Center,• Damage in shipment,• Alteration, misuse or improper installation,• Thermostats and safety valves with broken capillary tubes,• Accessories — spatulas, forks, steak turners, grate lifters, oven brushes, scrapers, peels. etc.,• Freight — other than normal UPS charges,• Ordinary wear and tear.
INSTALLATION	<p>Leveling and installation of decks as well as proper installation and check out of all new equipment —per appropriate installation and use materials — is the responsibility of the dealer or installer, not the manufacturer.</p>
REPLACEMENT PARTS	<p>BAKERS PRIDE genuine Factory OEM parts receive a (90) day materials warranty effective from the date of installation by a BAKERS PRIDE Factory Authorized Service Center.</p>

This Warranty is in lieu of all other warranties, expressed or implied, and all other obligations or liabilities on the manufacturer's part. BAKERS PRIDE shall in no event be liable for any special, indirect or consequential damages, or in any event for damages in excess of the purchase price of the unit. The repair or replacement of proven defective parts shall constitute a fulfillment of all obligations under the terms of this warranty.



BAKERS PRIDE OVEN CO. INC

2205 S. Standard Avenue
Santa Ana, CA 92707

(714) 424-9380 Phone
(714) 424-9385 Fax

www.bakerspride.com Web Address