



## HIGH PERFORMANCE HEAVY DUTY FLOOR MODEL RADIANT CHAR BROILERS



**Model CH-6**  
with optional legs & casters,  
splash guard, plate shelf & work deck

### SPECIFICATIONS

Extra heavy duty radiant char broilers are designed for high volume broiling without charcoal or ceramic stones.

The CH Series features unitized construction. The entire chassis frame including the base is hand-crafted of 1/2" (13mm) to 1/4" (6mm) thick HRS and welded to form a single unit without fasteners. The sides and rear of the outer shell is made of heavy gauge CRS and is welded to the chassis frame to complete the unitized construction and finished with durable Baker Tone paint.

CH Series features 24" long (610mm) aluminized steel burners rated at 18,000 BTUH each (5.27kw) located every 5 1/4" (133mm). Each burner features a separate, independent operator-controlled valve. 14-gauge stainless steel heat deflector radiants are located directly above each burner for an even transfer of radiant heat to the broiling surface. Cast iron burners and cast iron radiants are optional.

Standard top grates are heavy-duty cast iron. A variety of different style grates are available and may be mixed and matched. Each grate may be adjusted independently in any of three tilting positions. Broiler grates are 23 3/4" deep (603mm) for maximum production.

Exterior measures 28 1/4" deep (718mm) plus 8" lintel plate/shelf (203mm) or 9 1/8" (232mm) work deck with plate shelf. Working height measures 33 1/2" (851mm) with legs, or 20" (508mm) without legs, plus 6 1/2" (165mm) back splash. Standard widths range from 33 1/2" (851mm) up to 75 3/4" (1924mm).

Standard features include 2" deep stainless steel slide-out water pans and grease drawer, rear gas connections and pressure regulator. CH Series may be built in for display cooking and exhibition kitchens. Legs sold separately.

One year limited parts and labor warranty.

## GAS CHAR BROILERS



- Model CH-6
- Model CH-8
- Model CH-10
- Model CH-12
- Model CH-14

### STANDARD FEATURES

- Heavy plate steel, welded unitized construction
- High performance 18,000 BTUH per burner every 5 1/4"
- Natural or LP gas
- Individual, operator-controlled, adjustable burner valves
- 14-gauge stainless steel radiant heat deflectors above each burner
- 8" deep lintel plate/shelf (203mm)
- 2" deep (51mm) stainless steel water pans
- Stainless steel grease drawer
- Back splash
- Pressure regulator
- One year limited parts & labor warranty

### OPTIONS & ACCESSORIES

- Cast iron burners
- Cast iron radiant heat deflectors
- Stainless steel exterior side panels
- Leg set
- Leg & caster set
- Stainless steel or Richlite work deck with plate shelf
- Custom cut-outs in work deck for sauce pans
- 4" deep water pans (102mm)
- Stainless steel splash guard
- Variety of top grates including meat grates, fish grates, floating rod grates and more
- Stainless steel heat shields
- Side gas connections
- Removable griddle plates
- Log holders for smoke assisted char broiling
- Gas connector hoses

### CERTIFICATIONS



BAKERS PRIDE OVEN COMPANY, INC.  
30 Pine Street, New Rochelle, NY 10801  
914/576-0200 • 1-800-431-2745 • fax 914/576-0605  
www.bakerspride.com

*Continuous product improvement is a policy of Bakers Pride Oven Company. Therefore, specifications and design are subject to change without notification*

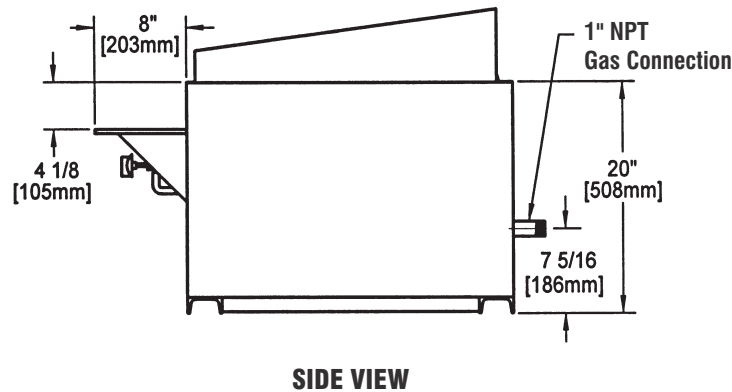
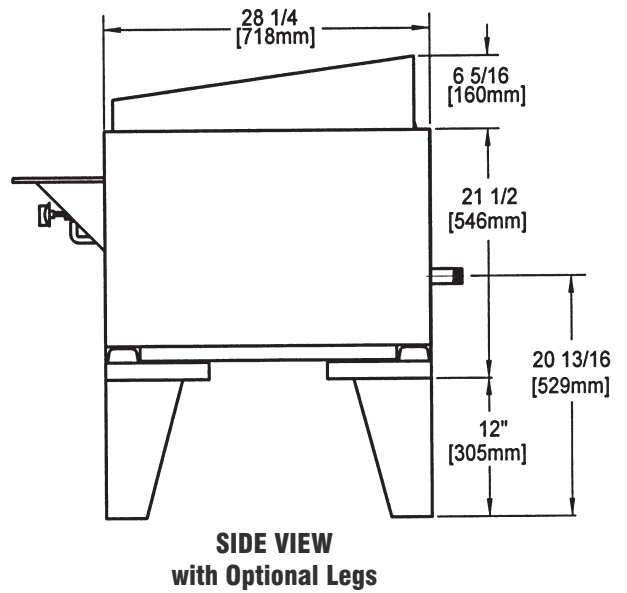
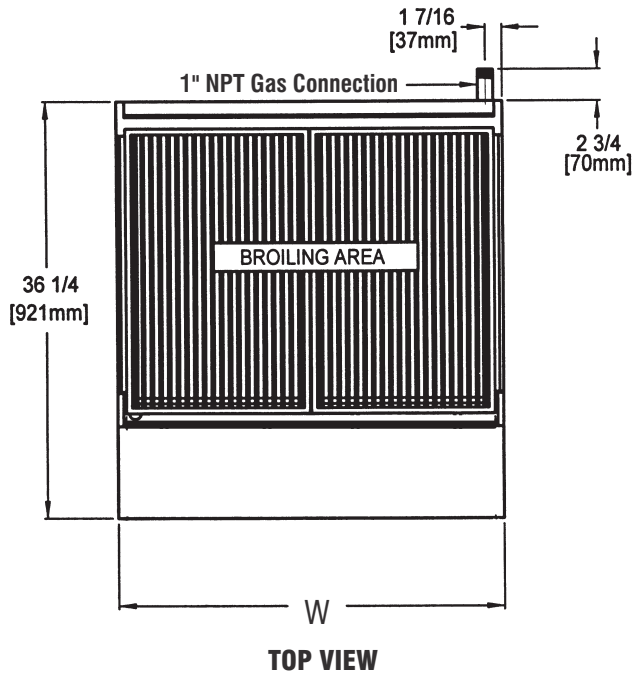

ALL DIMENSIONS NOMINAL

Model	Shipping Weight		Carton Dimensions				Crate Size			
	Lbs.	Kilos	Width Inches	mm	Depth Inches	mm	Height Inches	mm	Cubic Feet	Cubic Meter
CH-6	635	288	40	1168	40	1016	46	1188	42.8	1.17
CH-8	822	377	50	1270	40	1016	46	1188	53.2	1.47
CH-10	1065	483	60	1524	40	1016	46	1188	63.9	1.02
CH-12	1332	604	70	1778	40	1016	46	1188	74.5	2.05
CH-14	1405	637	80	2032	40	1016	46	1188	85.2	2.35

GAS SUPPLY			
Model	BTUH	KW	CONNECTION
CH-6	108,000	31.64	1"
CH-8	144,000	42.19	1"
CH-10	180,000	52.74	1"
CH-12	216,000	63.28	1"
CH-14	252,000	73.83	1"

SPECIFICATIONS										
Model	Broiling Area		# Top Grates	# of Burners	Overall Dimensions*					
	in.	mm			Width Inches	mm	Depth Inches	mm	Height Inches	mm
CH-6	31 1/2x24	826x610	5	6	33 1/2	851	36 1/4	921	40	1016
CH-8	43x24	1092x610	8	8	44	1117	36 1/4	921	40	1016
CH-10	53 3/4x24	1300x610	10	10	54 3/4	1381	36 1/4	921	40	1016
CH-12	64 1/2x24	1638x610	12	12	68 1/4	1657	36 1/4	921	40	1016
CH-14	74 3/4x24	1899x610	14	14	75 3/4	1924	36 1/4	921	40	1016

MINIMUM CLEARANCES		
	Inches	mm
Right	0	0
Left	0	0
Rear	0	0

\* From non-combustible construction  
 • Install only with non-combustible material above grate level

\*Height includes 4" (102 mm) optional legs