



**INSTALLATION
AND
OPERATING
INSTRUCTIONS**



Griddles

Models: XSG, XTG, XMG-24, -36, -48, -60, -72

INTENDED FOR OTHER THAN HOUSEHOLD USE

RETAIN THIS MANUAL FOR FUTURE REFERENCE



FOR YOUR SAFETY: Do not store or use gasoline or other flammable vapors and liquids in the vicinity of this or any other appliance.



WARNING: Improper installation, adjustment, alteration, service or maintenance can cause property damage, injury or death. Read the Installation, Operating and Maintenance Instructions thoroughly before installing or servicing this equipment.



This equipment has been engineered to provide you with year round dependable service when used according to the instructions in this manual and standard commercial kitchen practices.

Instructions must be posted in a prominent location. All safety precautions must be taken in the event the user smells gas. Safety information can be obtained from your local gas supplier.



P/N U4179A 1/08

BAKERS PRIDE OVEN CO., INC.

30 Pine Street
New Rochelle, NY 10801

(914) 576-0200 Phone
(914) 576-0605 Fax

(800) 431-2745 US & Canada
www.bakerspride.com Web Address

CONTENTS

1. Installation Instructions	2	A Lighting Instructions	4
A Safety Precautions	2	B Shutdown Instructions	4
B Unpacking Instructions	3	3. Cleaning Instructions	5
C Gas Connections	3	4. Maintenance Instructions	5
D Electric Installation (XSG model only)	3	5. Wiring Diagram (XSG Only)	6
E Leveling Adjustment	4	6. Parts List & Exploded View	7
2. Lighting Instructions	4	7. Warranty	11

GAS SPECIFICATIONS

Model Number	Propane Gas BTU/HR @ 10" W.C.	Natural Gas BTU/HR @ 3.5" W.C.
XSG, XTG, XMG -24	60,000	60,000
XSG, XTG, XMG -36	90,000	90,000
XSG, XTG, XMG -48	120,000	120,000
XSG, XTG, XMG -60	150,000	150,000
XSG, XTG, XMG -72	180,000	180,000

XSG units are equipped with snap action thermostats and standing pilot systems. This griddle must have 115V, 60 Hz electrical power to operate the main burners. **This appliance will not operate during a power failure. No attempt should be made to operate this gas appliance during power failure.**

XTG units are equipped with throttle type thermostat and standing pilot (no pilot safety provided)

XMG units are equipped with manual gas valves, and standing pilot (no pilot safety provided). No griddle plate temperature control is provided.

1. INSTALLATION INSTRUCTIONS

A. SAFETY PRECAUTIONS

FOR YOUR SAFETY, THE FOLLOWING SAFETY PRECAUTIONS SHOULD BE FOLLOWED AND ENFORCED.

IF YOU SMELL GAS:

- SHUT OFF GAS SUPPLY TO APPLIANCE
- EXTINGUISH OPEN FLAMES
- IMMEDIATELY CALL YOUR GAS SUPPLIER

1. A separate gas shut-off valve should be installed in the gas line ahead of the unit, as required by codes.
2. **LIGHTING:** Follow the instructions on page 5.
3. At least 24 inches must be provided at the front of unit for servicing.
4. When installing, never enclose the bottom area of the unit with a raised curb or other construction that would obstruct the flow of air into the unit.
5. This unit may be operated with 0" (side and back) minimum clearance to non-combustible construction materials.
6. This installation must conform to local codes, or in absence of local codes to the National Fuel Gas Code ANSI Z223.1, latest edition. In Canada it must conform to current National Standard CAN/CGA B 149.1 (natural gas) or CAN/CGA B 149.2 (propane) Installation Code for Gas Burning Appliances & Equipment.
7. **In MASSACHUSETTS:** All gas products must be installed by a "Massachusetts" licensed plumber or gas fitter. Ventilation hoods must be installed in accordance with NFPA-96, current edition, with interlocks as described in that standard.

8. Electrical diagram (model XSG only) is located on the right side of the unit.
9. The appliance and its individual shut-off valve must be disconnected from the gas supply piping system during any pressure testing of that system at test pressures in excess of 1/2" psi (3.45 kPa).
10. The appliance must be isolated from the gas supply piping system by closing its individual manual shut-off valve during any pressure testing of the gas supply piping system at test pressures equal to or less than 1/2" psi (3.45kPa).
11. This appliance must be installed under a ventilation hood.
12. Do not obstruct the flow of combustion and ventilation air.
13. The area around this or any other gas appliance must always be kept free and clear from combustibles.

RETAIN THIS MANUAL FOR FUTURE REFERENCE.

B. UNPACKING INSTRUCTIONS:

Carefully unpack the griddle and inspect immediately for shipping damages. Your Griddle was shipped in a carton designed to give maximum protection in normal handling. It was thoroughly inspected before leaving the factory and the carrier accepted and signed for it. File any claims for shipping damage or irregularities with the carrier.

C. GAS CONNECTIONS

A separate gas shut off valve (supplied with unit) must be installed in the gas line ahead of the unit, as required by codes (see Fig. A).. Gas supply line must be 3/4" or larger. If flexible semi rigid connections are used, the inside diameter must be the equivalent of 3/4" iron pipe or larger. All connections of the flexible and semi rigid type must be AGA listed and comply with applicable ANSI standards. Make sure gas piping is clean and free of dirt, piping compound and obstruction. To insure maximum operating efficiency, this appliance must be connected with a Gas Supply Line of solid pipe or with a Commercial Type Flexible Connector with I.D. (inside diameter) equal or larger than the gas pipe inlet on this appliance.

CAUTION: BEFORE LIGHTING, CHECK ALL JOINTS IN THE GAS SUPPLY LINE FOR LEAKS. USE SOAP AND WATER SOLUTION. DO NOT USE OPEN FLAME.

If the gas connections are leak-free, the unit is ready to use. Follow the lighting instructions.

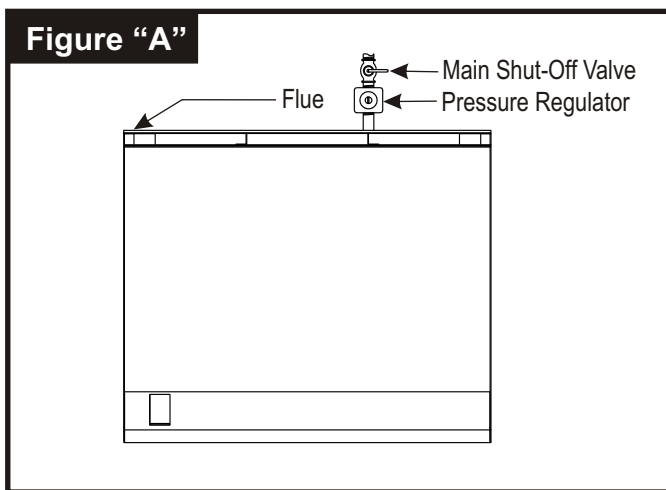

D. ELECTRIC INSTALLATION (XSG ONLY)

This appliance when installed must be electrically grounded in accordance with local codes, or in the absence of local codes, with the *National Electrical Code, ANSI/NFPA 70*, or the *Canadian Electrical Code, CSA C22.2*, as applicable.

The installation of electric wiring from the electric meter, the main control box, and the outlet to the electric appliance must be electrically grounded in accordance with local codes, or in the absence of local codes with the National Electric Code ANSI/NFPA 70. In Canada, follow the Canadian Electric Code CSA-C 22.2. All work should be done by qualified installation personnel.

Electrical diagram (model XSG only) is located on the right side of the unit.

WARNING-ELECTRICAL GROUNDING INSTRUCTION

This appliance is equipped with a three-prong (grounding) plug for your protection against shock

hazard and should be plugged directly into a properly grounded three-prong receptacle. Do not cut or remove the grounding prong from this plug.

Thermostats do not have to be turned off to turn off your griddle. The ON/OFF toggle switch allows the thermostats to remain set at your cooking temperature when the griddle is OFF. When the main switch is ON the griddle automatically heats to your pre-set cooking temperature.

Red indicator lights next to the thermostats are ON when the burners are in operation. When the set temperature is reached, the light will go OFF.

E. LEVELING ADJUSTMENT

All griddles are equipped with adjustable legs to provide a means for proper leveling during installation. The griddle can be leveled by turning the bottom of the legs until the desired position is achieved. After leveling, the manifold should then be connected to the gas line.

2. LIGHTING INSTRUCTIONS

A. LIGHTING INSTRUCTIONS

1. Turn off all thermostats or gas controls and main Shut-off valve and wait 5 minutes.
2. Turn the main gas valve to ON position and light standing pilots through the holes in the front panel. (FIG. B) The pilot assembly is located about 10" into the unit from the front panel. Use a BBQ match or a lighter at least 10" long. Alternatively pilots are also accessible from the bottom of the unit and the distance is approximately 6". Insert a match or a lighter from the bottom of the unit while watching through the lighting hole in the front panel to make sure all pilots light correctly.
3. Repeat the above step for all standing pilots. There should be slight yellow tip on the pilot flame. Make sure all the pilots are lit. Pilot should be approximately 1/2" - 3/4" in height. Adjust as required by turning the pilot adjusting screw located on the manifold pipe.
4. Turn the toggle switch on the front panel to ON position (XSG model only)
5. Set all thermostats to desired temperature. All burners must light and burn evenly. Flames are to be blue with little or no traces of white or yellow. If they exhibit excessive white or yellow flames, adjust the burner shutters. Re-light burners and re-check. Repeat as required.
6. The red indicator light on XSG model will indicate that the main burner is in operation.
7. To relight follow steps 1-5.

B. SHUTDOWN INSTRUCTIONS

For complete shutdown turn all thermostats, toggle switch (model XSG ONLY) and main gas valve to OFF position.

EQUIPMENT PREPARATION

The griddle is shipped with protective coatings of oil and/or grease. Remove the griddle plate coating with a commercial de-greaser just prior to its first cooking use. After a thorough cleaning, apply a high temperature, salt free frying oil and your unit is ready to use. If the griddle is to be shut down for an extended period, put a heavy coat of clean grease back over the griddle plate.

Wipe the remaining cabinet parts down with a hot, wet cloth to remove any shipping dust and protective oil. Remove anything that may be in the grease drawer.

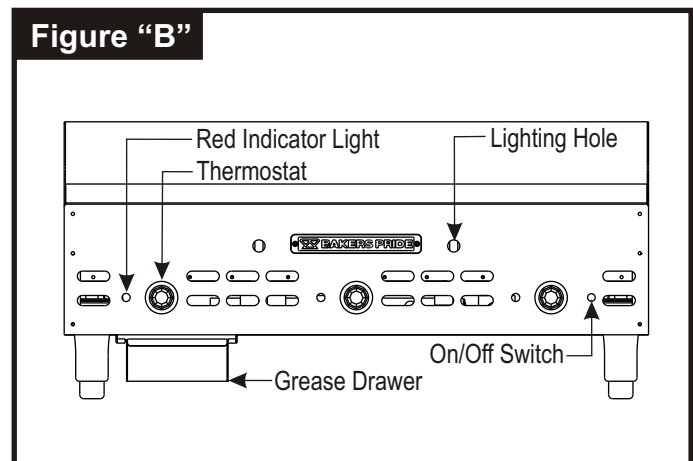

CAUTION: Care must be exercised not to overheat the griddle plate on initial start-up by setting the controls above normal operating temperature. Overheating may cause the plate to warp and will carbonize the grease (this will cause sticking).



OPERATING SEASONING

A new griddle surface must be seasoned to do a good cooking job and to prevent rust. The metal surface of the griddle is porous. Food tends to get trapped in these pores and stick; therefore, it is important to "season" or "fill up" these pores with griddling "fat" before cooking on any metal surfaced griddle. Seasoning gives the surface a slick, hard finish from which the food will release easily.

To season, heat the griddle to a low (300°F to 350°F) temperature and pour on a small amount of cooking oil, about one ounce per square foot of surface. Spread the oil over the entire griddle surface with a cloth to create a thin film. Wipe off any excess oil with a cloth.

Repeat the procedure 2 to 3 times until the griddle has a slick, mirror-like surface.



CAUTION: This griddle plate is steel, but the surface is relatively soft and can be scored or dented by carelessly using a spatula. Be careful not to dent, scratch, or gouge the plate surface. Do not try to knock off loose food that may be on the spatula by tapping the corner or the edge of the spatula on the griddle surface.



3. CLEANING

NEVER clean any electrical unit by immersing it in water. Turn unit off and allow it to cool down before surface cleaning. Always clean equipment thoroughly before first use. Clean unit daily. Except where noted on charts: use warm, soap water. Mild cleansers and PLASTIC scouring pads may be used to remove baked on food and water scale on metal units. Unplug electrical units before cleaning or servicing. All service should be performed by a Bakers Pride authorized service agency.

Empty the grease drawer as required. Do not allow grease to overflow. Clean the unit regularly. A clean unit looks better, lasts longer and performs better.

KEEP GRIDDLE PLATE SURFACE CLEAN (See below). To produce evenly cooked, perfectly browned griddle products, keep the griddle free of carbonized grease.

Carbonized grease on the surface hinders the transfer of heat from the griddle surface to food. This results in spotty browning and loss of cooking efficiency and, worst of all, carbonized grease tends to cling to the griddled foods, giving them a highly unsatisfactory and unappetizing appearance. To keep the griddle clean and operating at peak efficiency, follow these simple instructions.

AFTER EACH USE, clean the griddle with a wire brush, fine grain stone or flexible spatula. Occasionally clean the griddle with vinegar when the griddle is cool, or club soda while the griddle is still hot. This will help maintain a clean, new look.

ONCE A DAY, thoroughly clean splash back, sides and front. Remove the grease drawer, empty and wash out in the same manner as any ordinary cooking utensil.

ONCE A WEEK, clean the griddle surface thoroughly. If necessary, use a griddle stone, wire brush or steel wool on the surface. Rub with the grain of the metal while the griddle is still warm. A detergent may be used on the plate surface to help clean it, but care must be taken to be sure the detergent is thoroughly removed. After removal of the detergent, the surface of the plate should then be covered with a thin film of oil to prevent rusting. Clean stainless steel surfaces with a damp cloth and polish with a soft, dry cloth. To remove discoloration, use a non-abrasive cleaner. After each "weekly" type of cleaning, the griddle must be re-seasoned. If the griddle usage is very high, consider going through the "weekly" cleaning procedures more often than once a week.

4. MAINTENANCE INSTRUCTIONS

A. MAINTENANCE

To provide proper operation and insure the safety of the user, this equipment must be maintained and serviced by a trained maintenance person or an authorized service agency at regular intervals. Disconnect the power supply to appliance before cleaning or servicing.

1. Burner ports must be thoroughly cleaned. Venturi must be free from grease and lint.
2. All places where oil, grease or food can accumulate must be kept clean all the time.
3. Pilot light must be kept clean and adjusted at the proper flame height to assure constant ignition and to prevent fire flash-outs caused by delayed ignition.
4. Appliance flue has to be kept clean and free of any obstruction to ensure unrestricted flow of combustion products from the unit.
5. Carelessness, abusive handling, or altering equipment can shorten the life of the equipment and jeopardize the limited warranty offered by Baker's Pride.

If you have any questions concerning the installation, operation, maintenance or service of this product please contact Baker's Pride's Technical Service Department at (800) 431-2745 US & Canada.

TROUBLESHOOTING CHART

PROBLEM	PROBABLE CAUSE	SOLUTION
Burners & pilots will not turn on	Main gas supply to range is not turned on.	Turn on main gas supply.
Burners produce excessive carbon deposits	Incorrect gas type.	Supply correct type gas.
	Incorrect gas supply pressure.	Call local gas supplier.
	Incorrect orifices.	Call Baker's Pride authorized service center.
	Primary air not adjusted properly.	Adjust air shutter.
Pilot will not remain lit.	Pilot flame adjusted incorrectly.	Adjust pilot flame.
	Draft condition.	Remove draft.
Griddle doesn't seem hot enough	Orifices may be dirty/clogged.	When unit cools, check & clean orifices.
	Low gas pressure.	Increase gas pressure to 3.5" W.C. (Nat) or 10" W.C. (L.P.)
Griddle surface too hot	Thermostat set too high.	Reduce thermostat setting.
	Thermostat defective.	Replace thermostat.
Burners won't turn on (XSG only)	Unit unplugged.	Plug unit in.
	No power to outlet.	Replace fuse or reset circuit breaker.

5. WIRING DIAGRAM - MODEL XSG ONLY (See Figure C)

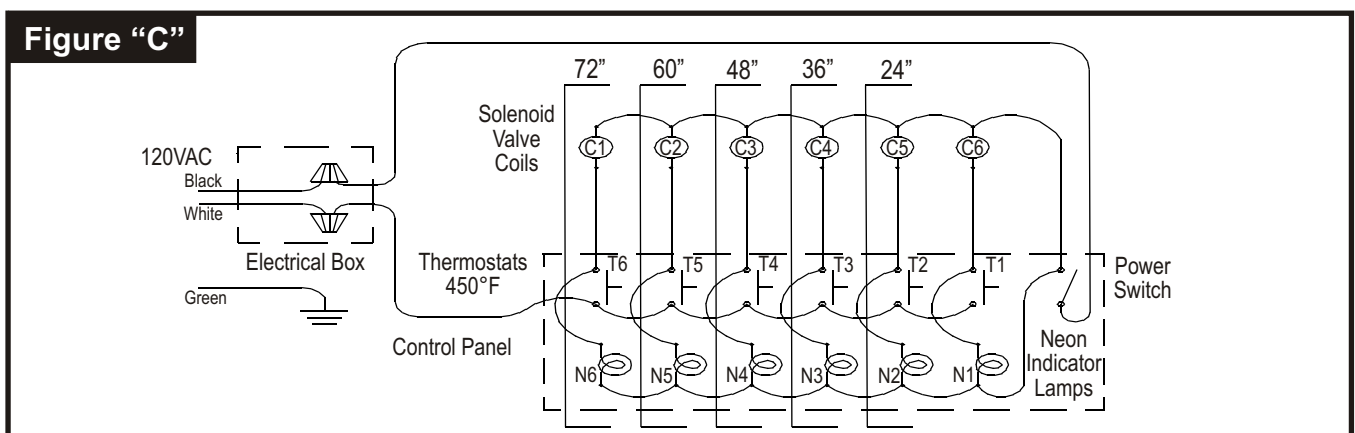

6. PARTS LIST & EXPLODED VIEW



XMG, XTG, XSG
-24, 36, 48, 60, 72
Gas Counter Top Griddles



30 Pine Street • New Rochelle • New York • 10801
 1 - 914 / 576 - 0200
 1 - 914 / 576 - 0605 fax
 1 - 800 - 431 - 2745 US & Canada
 www.bakerspride.com web address

Model XSG-24,36,48,60 & 72

EXPLODED VIEW

Cookline
 SERIES

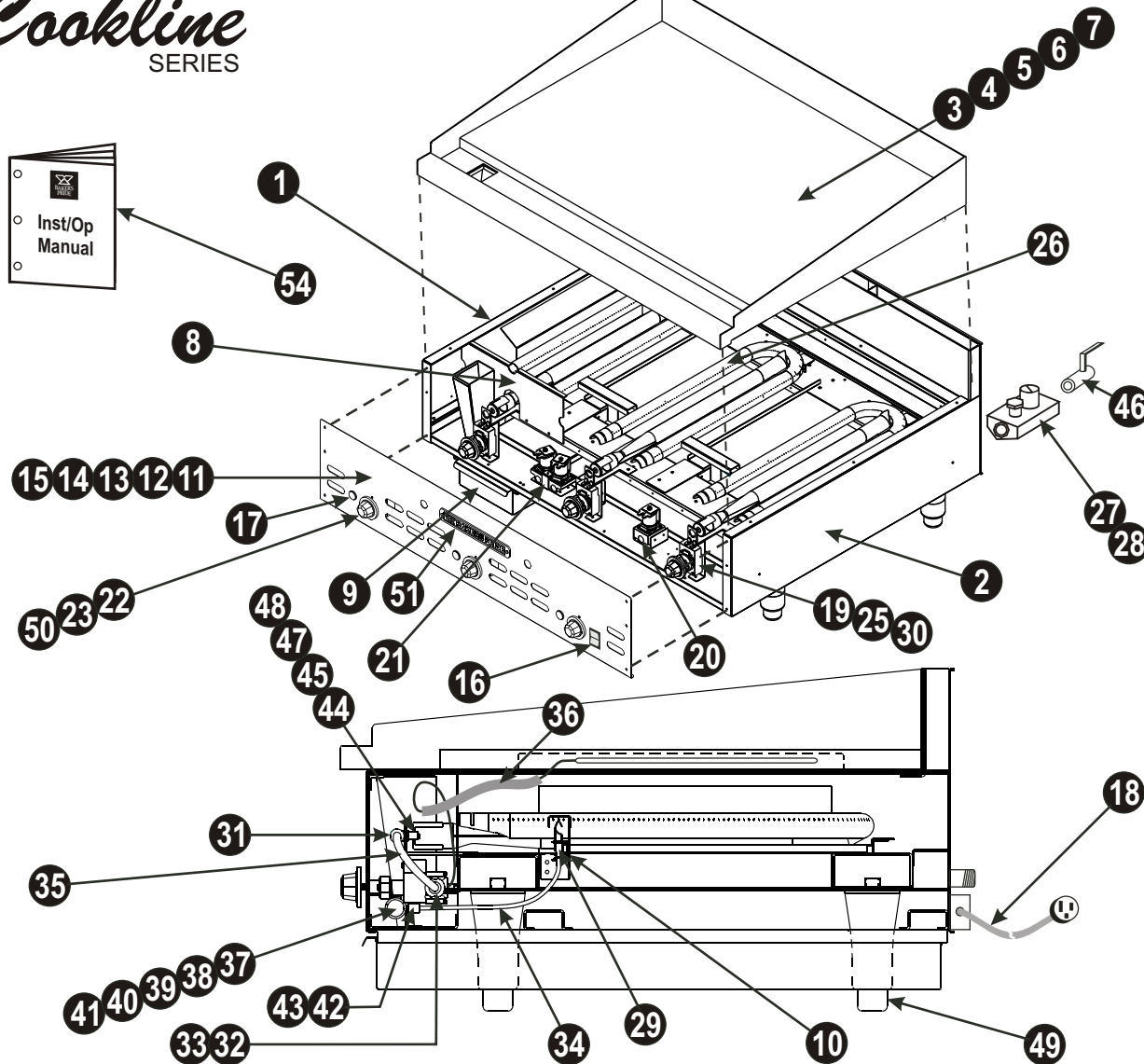

Additional Hardware Not Shown

P/N	Description	P/N	Description	P/N	Description
N3068P	Pressure Tap Nozzle	Q1407A	Screw, #10 x 1/2", Hex Hd, Slot	Q2038A	Weld Screw, 1/4-20 x 5/8"
P1035A	Wire Nut	Q1412A	Screw, #10 24 x 3/8", Truss Hd, Slot	Q2046A	Nut, 1/4-20, Hex, Lock
Q1001A	Screw, 6-32 x 1/4", Rnd Hd, Slot	Q1472A	Screw, 1/4-20 x 1/4", Button Hd	Q2055A	Screw, 1/4-20 x 2-1/4, Flat Hd, Slot
Q1401A	Screw, 10-32 x 1/2", Pan Hd, Slot	Q2002A	Screw, 1/4-20 x 1/2", Truss Hd, Slot	Q2335A	Nut, 3/4-10, Hex, Heavy
Q1406A	Screw, #10 x 1/2", Truss Hd, Slot	Q2027A	Screw, 1/4-20 x 1/2", Hex Hd	Q3044A	Washer, Thk, Flat

Note: When ordering, ALWAYS specify Part #, Model #, Serial #, Voltage/Phase & type of Gas.

U6021A 5/07

Model Number - Width			Serial Number	Type of Gas	Voltage, Amps
XMG	<input type="checkbox"/> -24"	<input type="checkbox"/> -60"	_____	Natural <input type="checkbox"/>	120 Volts, 1 Amp (Model XSG Only)
XTG	<input type="checkbox"/> -36"	<input type="checkbox"/> -72"		L.P. <input type="checkbox"/>	
XSG	<input type="checkbox"/> -48"	<input type="checkbox"/>		Other <input type="checkbox"/>	

Item	XTG	XMG	XSG	Description
	Part Number			
1	G7002K	G7002K	G7002K	Outer Side, Left
2	G7003K	G7003K	G7003K	Outer Side, Right
3	G8001U	G8106U	G8106U	Griddle Plate Assy 24"
4	G8002U	G8102U	G8102U	Griddle Plate Assy 36"
5	G8003U	G8103U	G8103U	Griddle Plate Assy 48"
6	G8004U	G8104U	G8104U	Griddle Plate Assy 60"
7	G8005U	G8105U	G8105U	Griddle Plate Assy 72"
8	G8057K	G8057K	G8057K	Heat Shield, Front
9	G8061K	G8061K	G8061K	Grease Drawer
10	G8062U	G8062U	G8062U	Pilot Bracket Assembly
11	G8077U	G8097K	G8017U	Control Panel Assy, 24"
12	G8093U	G8076K	G8018U	Control Panel Assy, 36"
13	G8094U	G8098K	G8019U	Control Panel Assy, 48"
14	G8095U	G8099K	G8020U	Control Panel Assy, 60"
15	G8096U	G8100K	G8021U	Control Panel Assy, 72"
16	-----	-----	M1307A	Switch, Rocker
17	-----	-----	P1168A	Indicator Light, Red
18	-----	-----	P6004A	Power Cord
19	-----	R3032A	-----	Valve, Lml-15
20	-----	-----	R3200A	Solenoid Valve, Single
21	-----	-----	R3201A	Solenoid Valve, Dual
22	-----	S1416A	-----	Knob, Gas Valve On-Off
23	-----	-----	S1419A	Knob 450°F, KX Thermostat
24	-----	-----	U1363A	Label, Wiring Diagram (Not Shown)
25	-----	-----	M1461A	KX Thermostat, 450°F (w/Knob & Sleeve)
26	L5104A	L5104A	L5104A	Burner, Horse Shoe
27	M1009A	M1009A	M1009A	Pressure Regulator, 3/4", 10" WC, LP
28	M1184A	M1184A	M1184A	Pressure Regulator, 3/4", 3.5" WC
29	M1463A	M1463A	M1463A	Pilot Burner
30	M1465A	-----	-----	BJ Thermostat, 450°F (w/Knob & Sleeve)
31	N3083A	N3083A	N3083A	Brass Orifice Fitting, Elbow 3/8"
32	N3084A	N3084A	N3084A	Elbow 3/8", Brass, Compression
33	N3089A	N3089A	N3089A	Brass Fitting, Compression 3/8"
34	N5854A	N5854A	N5854A	Aluminum Tubing 3/16"
35	N5856A	N5856A	N5856A	Aluminum Tubing 3/8"
36	P1029A	P1029A	P1029A	Sleeve, 1/4" Thermo-Flex Insulation
37	R1153A	R1153A	R1142A	Manifold 24"
38	R1154A	R1154A	R1143A	Manifold 36"
39	R1155A	R1155A	R1144A	Manifold 48"
40	R1156A	R1156A	R1145A	Manifold 60"
41	R1157A	R1157A	R1146A	Manifold 72"
42	R3020A	R3020A	R3020A	Valve, Pilot Double
43	R3021A	R3021A	R3021A	Valve, Pilot Single
44	R3023A	R3023A	R3023A	Orifice, Blank
45	R3205A	R3205A	R3205A	Orifice #38, Nat Gas
46	R3206A	R3206A	R3206A	Valve, Gas Shut-off
47	R3222P	R3222P	R3222P	Orifice #52, LP Gas
48	R3250P	R3250P	R3250P	Orifice #53, But/Prop Gas
49	S1395A	S1395A	S1395A	Leg 6", Adjustable
50	S1420A	-----	-----	Knob 450°F, BJ Thermostat
51	U1044A	U1044A	U1044A	BP Logo 8" Nameplate
52	U1362A	U1362A	U1362A	Label, Lighting Instruction (Not Shown)
53	U1364A	U1364A	U1364A	Label, Warning (Not Shown)
54	U4179A	U4179A	U4179A	Installation/Operation Manual

Note: When ordering, ALWAYS specify Part #, Model #, Serial #, Voltage/Phase & type of Gas.

U6021A 5/07

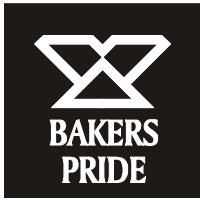

7. BAKERS PRIDE LIMITED WARRANTY

30 Pine Street New Rochelle, New York 10801
914 / 576 - 0200 ♦ US & Canada: 1 - 800 - 431 - 2745 ♦ fax 914 / 576 - 0605

- WHAT IS COVERED** This warranty covers defects in material and workmanship under normal use, and applies only to the original purchaser providing that:
- ♦ The equipment has not been accidentally or intentionally damaged, altered or misused;
 - ♦ The equipment is properly installed, adjusted, operated and maintained in accordance with National and local codes, and in accordance with the installation instruction provided with the product;
 - ♦ The serial number rating plate affixed to the equipment has not been defaced or removed.
- WHO IS COVERED** This warranty is extended to the original purchaser and applies only to equipment purchased for use in the U.S.A.
- COVERAGE PERIOD** Full size gas and electric deck ovens: Two (2) year limited parts and labor: Cyclone Convection Ovens: BCO Models: One (1) Year limited parts and labor; GDCO Models: Two (2) Year limited parts and labor; CO II Models: Two (2) Year limited parts and labor; (5) Year limited door warranty.
All Other Products: One (1) Year limited parts and labor.
Warranty period begins the date of dealer invoice to customer or ninety (90) days after shipment date from BAKERS PRIDE - whichever comes first.
- WARRANTY COVERAGE** This warranty covers on-site labor, parts and reasonable travel time and travel expenses of the authorized service representative up to (100) miles, round trip, and (2) hours travel time. The purchaser, however, shall be responsible for all expenses related to travel, including time, mileage and shipping expenses on smaller counter models that may be carried into a Factory Authorized Service Center, including the following models: PX-14, PX-16, PI8, and BK-18.
- EXCEPTIONS** All removable parts in BAKERS PRIDE Char-broilers, including but not limited to: Burners, Grates, Radiants, Stones and Valves, are covered for a period of SIX MONTHS.
All Ceramic Baking Decks are covered for a period of THREE MONTHS. The installation of these replacement decks is the responsibility of the purchaser.
The extended Cyclone door warranty years 3 through 5 is a parts only warranty and does not include labor, travel, milage or any other charges.
- EXCLUSIONS**
- ♦ Negligence or acts of God,
 - ♦ Thermostat calibrations after (30) days from equipment installation date,
 - ♦ Air and Gas adjustments,
 - ♦ Light bulbs,
 - ♦ Glass doors and door adjustments.
 - ♦ Fuses,
 - ♦ Char-broiler work decks and cutting boards,
 - ♦ Tightening of conveyor chains,
 - ♦ Adjustments to burner flames and cleaning of pilot burners,
 - ♦ Tightening of screws or fasteners.
 - ♦ Failures caused by erratic voltages or gas supplies,
 - ♦ Unauthorized repair by anyone other than a BAKERS PRIDE Factory Authorized Service Center,
 - ♦ Damage in shipment,
 - ♦ Alteration, misuse or improper installation,
 - ♦ Thermostats and safety valves with broken capillary tubes.
 - ♦ Accessories - spatulas, forks, steak turners, grate lifters, oven brushes, scrapers, peels, etc.,
 - ♦ Freight - other than normal UPS charges,
 - ♦ Ordinary wear and tear.
- INSTALLATION** Leveling and installation of decks, as well as proper installation and check out of all new equipment - per appropriate installation and use materials - is the responsibility of the dealer or installer, not the manufacturer.
- REPLACEMENT PARTS** BAKERS PRIDE genuine Factory OEM parts receive a (90) day materials warranty effective from the date of installation by a BAKERS PRIDE Factory Authorized Service Center.

This Warranty is in lieu of all other warranties, expressed or implied, and all other obligations or liabilities on the manufacturers part. BAKERS PRIDE shall in no event be liable for any special, indirect or consequential damages, or in any event for damages in excess of the purchase price of the unit. The repair or replacement of proven defective parts shall constitute a fulfillment of all obligations under the terms of this warranty.

Form #U4177A 1/07



BAKERS PRIDE OVEN CO., INC.

30 Pine Street
New Rochelle, NY 10801

(914) 576-0200 Phone
(914) 576-0605 Fax

(800) 431-2745 US & Canada
www.bakerspride.com WebAddress