



**L-R RADIANT &
L-GS GLO-STONE SERIES
HIGH PERFORMANCE
LOW PROFILE COUNTER TOP
STYLE GAS CHAR BROILER**



Model L-24R with floating rod top grate and optional 4" legs

SPECIFICATIONS

Low Profile Counter Top style char broiler is designed for high volume char broiling in natural or LP gas. L-R Series includes 14-gauge stainless steel radiants above each burner for maximum heat distribution to cooking surface. The L-GS series features Glo Stones for extra high heat and flame-flare. Radiants and Glo Stones are interchangeable without tools and may be mixed and matched on the same broiler. High performance, clog-proof, aluminized steel burners are rated at 15,000 BTUH each and located approximately every 4". Each burner features a separate, independent, operator-controlled valve with stand-by position.

Standard grates are fabricated of 1/2" diameter steel floating-rods. A variety of different style grates are optional and may be mixed or matched. Each grate may be adjusted independently in any of four tilting positions. Broiler grates are 24" deep (610mm) for maximum production.

Heavy duty stainless steel exterior, interior and combustion chamber. Broiler cabinet construction is double walled with fully insulated sides, back and bottom.

The exterior measures 27 1/2" deep (699mm) plus 6" (152mm) stainless steel work deck by 13 1/2" high (343mm) to front broiling surface and 18" high (457mm) in rear plus optional 4" legs (102mm). Broiler may be used with or without legs (provided). Widths are available in six sizes from 24" (610mm) to 84" (2134mm).

Standard features include a modular 6" deep (152mm) stainless steel, front mounted work deck, stainless steel front mounted grease trough, 1 1/2" deep (38mm) stainless steel slide-out grease and water pans, rear gas connection and pressure regulator.

Job _____ Item # _____

GAS COUNTER TOP CHAR BROILERS 

RADIANT MODELS

- Model L-24R
- Model L-30R
- Model L-36R
- Model L-48R
- Model L-60R
- Model L-72R
- Model L-84R

GLO-STONE MODELS

- Model L-24GS
- Model L-30GS
- Model L-36GS
- Model L-48GS
- Model L-60GS
- Model L-72GS
- Model L-84GS

STANDARD FEATURES

- Stainless steel exterior, interior and combustion chamber
- Easy-Lite / Always-Lit crossover pilot tube
- Double-walled, fully insulated construction
- High performance, 15,000 BTUH burners
- Up to 300,000 BTUH per broiler, natural or LP gas
- Independently controlled, adjustable valves for each burner with stand-by position
- Heavy-duty 14-gauge stainless steel radiants above each burner or Glo Stones – may be mixed & matched
- 1 1/2" Deep stainless steel, slide out grease drawer & water pans
- Individually adjustable, 4-position tilting, floating rod type grates – cast iron & meat grates available at no extra charge
- Rear gas connection & pressure regulator
- Belly bar / towel rack
- One year limited parts and labor warranty

OPTIONS & ACCESSORIES

- 18,000 BTUH high heat burners
- Cast iron radiants
- Glo Stones or radiants (field convertible)
- Removable, steel griddle plate / breakfast griddle
- Fish, meat, cast iron, square-rod grates or fajita grates
- Extra deep modular stainless steel work decks
- Cut outs in extra deep work decks for sauce pans
- 48" Gas connector hoses with or without restraining cable
- Stainless steel splash guards
- Overhead back shelves with additional grates
- Condiment rails
- Extended water pans
- Natural wood smoke essence box

CERTIFICATIONS



BAKERS PRIDE OVEN COMPANY, INC.
30 Pine Street, New Rochelle, NY 10801
914/576-0200 • 1-800-431-2745 • fax 914/576-0605
web: www.bakerspride.com

Continuous product improvement is a policy of Bakers Pride Oven Company. Therefore, specifications and design are subject to change without notification

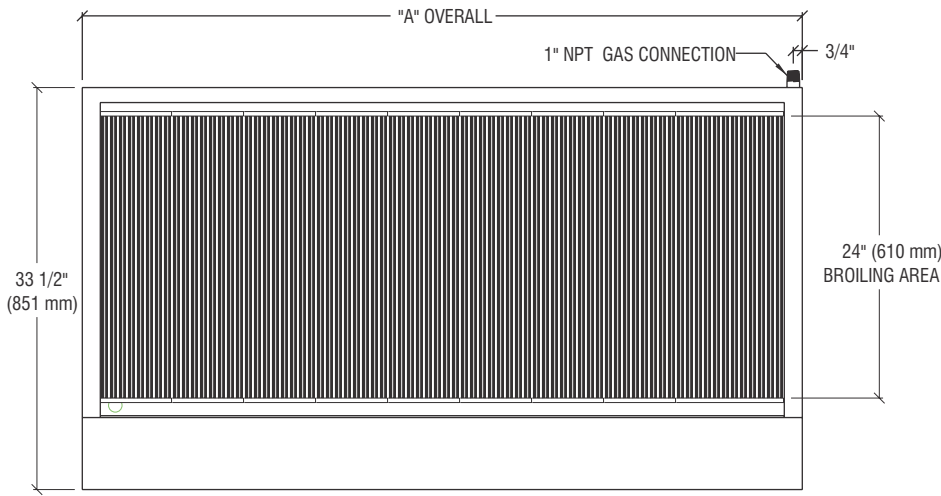

TOP VIEW

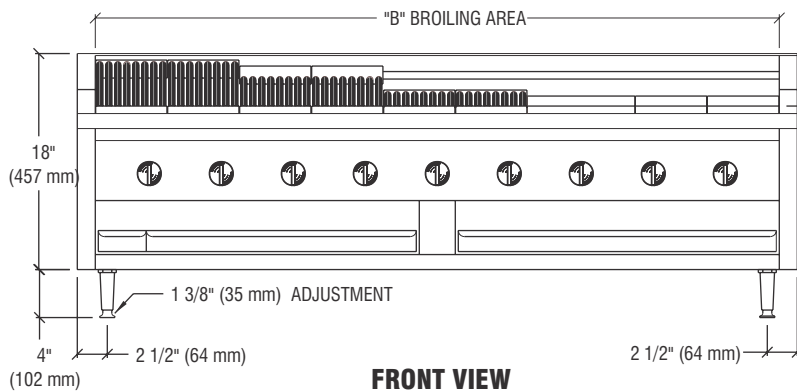

FRONT VIEW
with optional wire racks

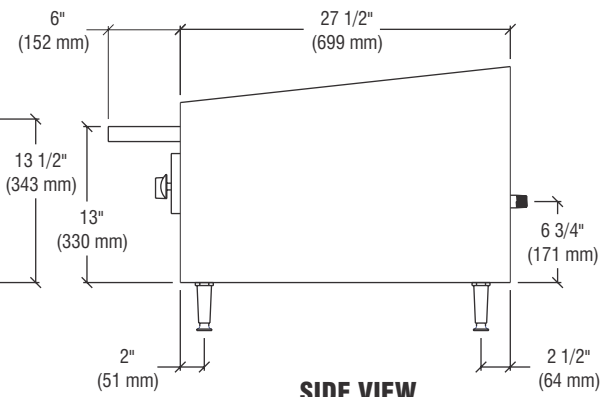

SIDE VIEW

ALL DIMENSIONS NOMINAL

Model		Shipping Weight		Carton Dimensions				Crate Size			
		Lbs.	Kilos	Width Inches	mm	Depth Inches	mm	Height Inches	mm	Cubic Feet	Cubic Meter
L-24R	L-24GS	240	108	36	914	33	838	35	889	23.7	.7
L-30R	L-30GS	290	131	36	914	33	838	35	889	23.7	.7
L-36R	L-36GS	395	178	53	1346	40	1016	37	940	44.4	1.2
L-48R	L-48GS	400	180	53	1346	40	1016	37	940	44.4	1.2
L-60R	L-60GS	530	239	35	889	69	1753	28	711	39.1	1.1
L-72R	L-72GS	830	377	36	914	74	1880	34	864	52.4	1.4
L-84R	L-84GS	1230	559	36	914	86	2184	34	864	60.9	1.8

Under 500 lbs = Shipping Class # 70
Over 500 lbs = Shipping Class # 85

	Non-Combustible Construction*		Combustible Construction**	
	Inches	mm	Inches	mm
Left Side	0	0	10	254
Right Side	0	0	10	254
Rear	0	0	10	254
Bottom †	0	0	0	0

* In European Community Countries and North America.
** In European Community Countries only. NOT for North America.
† When used with factory supplied 4" legs (102mm).

Model		Broiling Area		# Top Grates	# of Burners	Overall Dimensions*					
		in.	mm			Width Inches	mm	Depth* Inches	mm	Height* Inches	mm
L-24R	L-24GS	21 x 24	534 x 610	4	5	24	610	33 1/2	851	18	457
L-30R	L-30GS	27 x 24	686 x 610	5	6	30	762	33 1/2	851	18	457
L-36R	L-36GS	33 x 24	838 x 610	6	8	36	915	33 1/2	851	18	457
L-48R	L-48GS	45 x 24	1143 x 610	8	11	48	1219	33 1/2	851	18	457
L-60R	L-60GS	57 x 24	1448 x 610	10	14	60	1524	33 1/2	851	18	457
L-72R	L-72GS	69 x 24	1753 x 610	12	17	72	1829	33 1/2	851	18	457
L-84R	L-84GS	81 x 24	2057 x 610	14	20	84	2134	33 1/2	851	18	457

*Height excludes 4" (102 mm) standard legs
*Depth includes 6" (152 mm) work deck

Model	BTUH	KW	CONNECTION
L-24R L-24GS	75,000	21.98	1"
L-30R L-30GS	90,000	26.37	1"
L-36R L-36GS	120,000	35.16	1"
L-48R L-48GS	165,000	48.35	1"
L-60R L-60GS	210,000	61.53	1"
L-72R L-72GS	255,000	74.72	1"
L-84R L-84GS	300,000	87.90	1"



BAKERS PRIDE OVEN COMPANY, INC.
30 Pine Street, New Rochelle, NY 10801
914/576-0200 • 1-800-431-2745 • fax 914/576-0605
web: www.bakerspride.com

Continuous product improvement is a policy of Bakers Pride Oven Company. Therefore, specifications and design are subject to change without notification

TS:06/05